

REVISION HISTORY				
REV	ECN	DESCRIPTION	DATE	APPROVED
A	F960052	RELEASE	8/21/1996	DJ
B	F960060	REVISED PER DETAILS	9/14/1996	DJ
C	F110141	DRAWN IN INVENTOR	6/28/2011	jmos

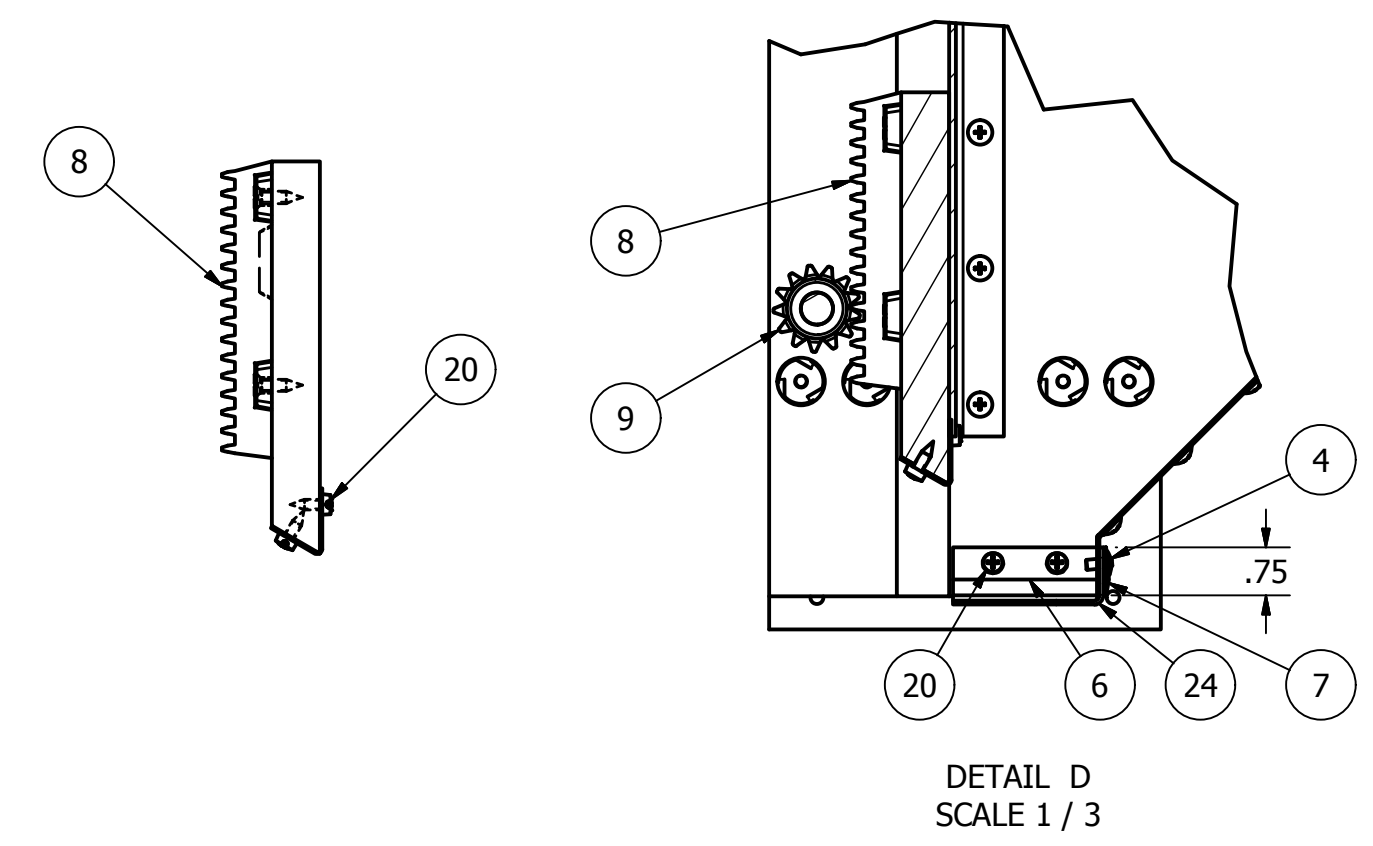
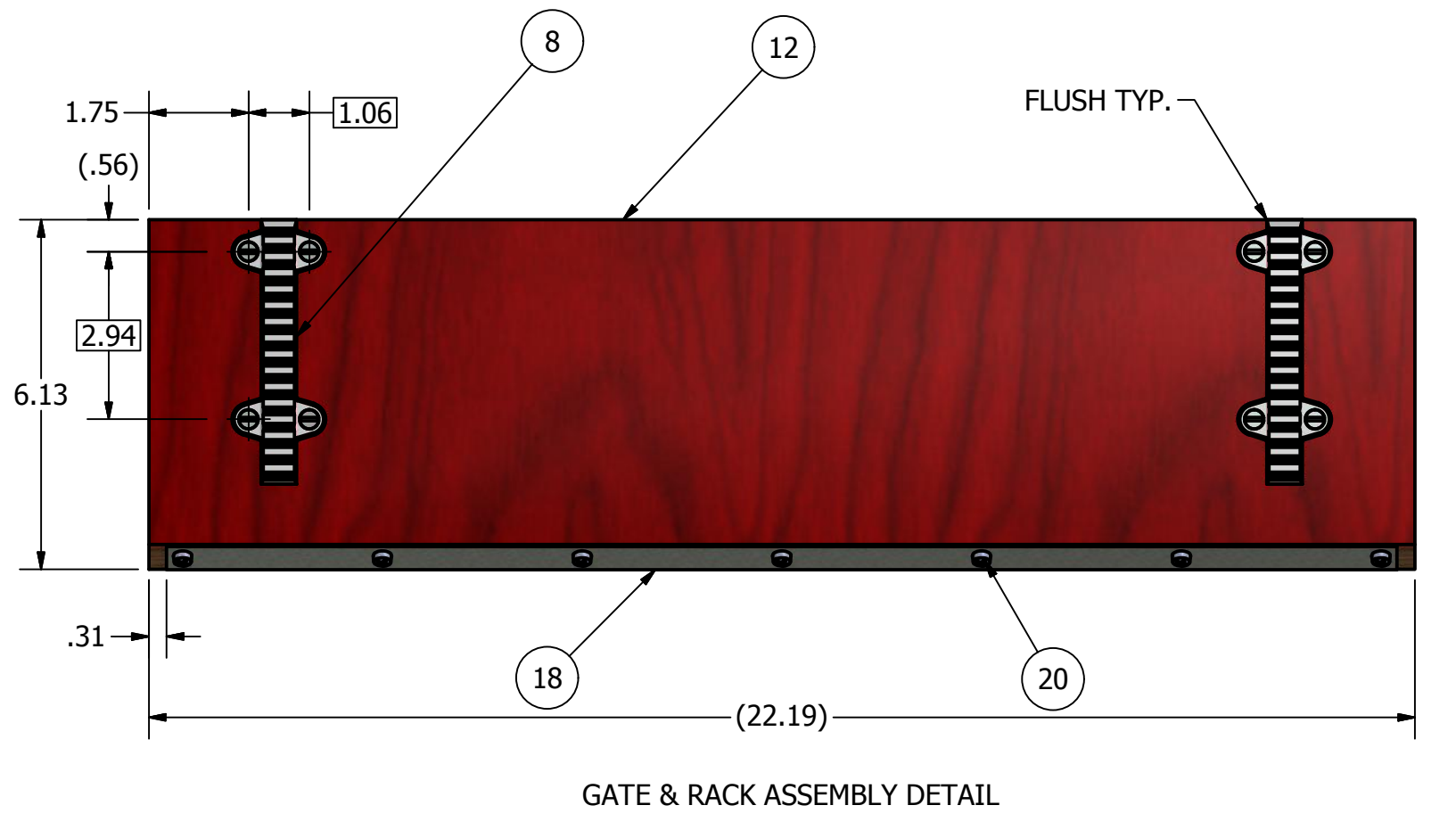
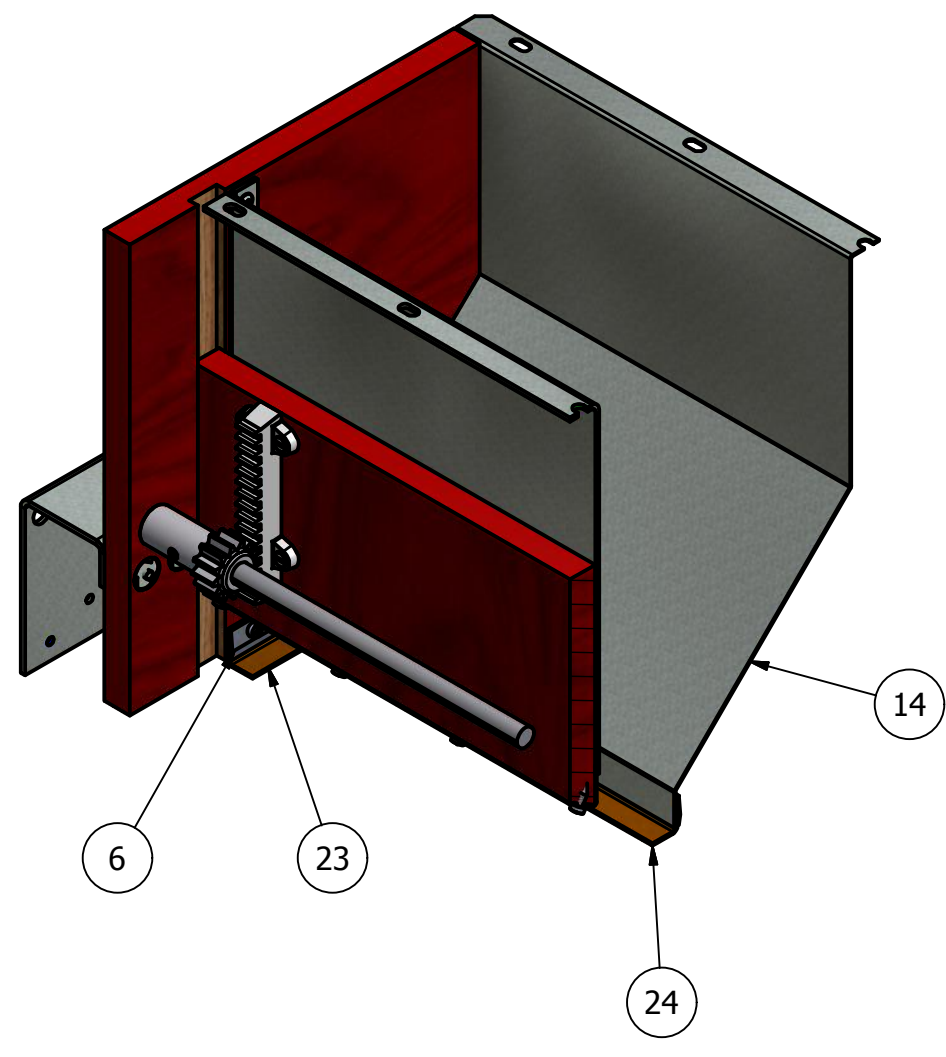
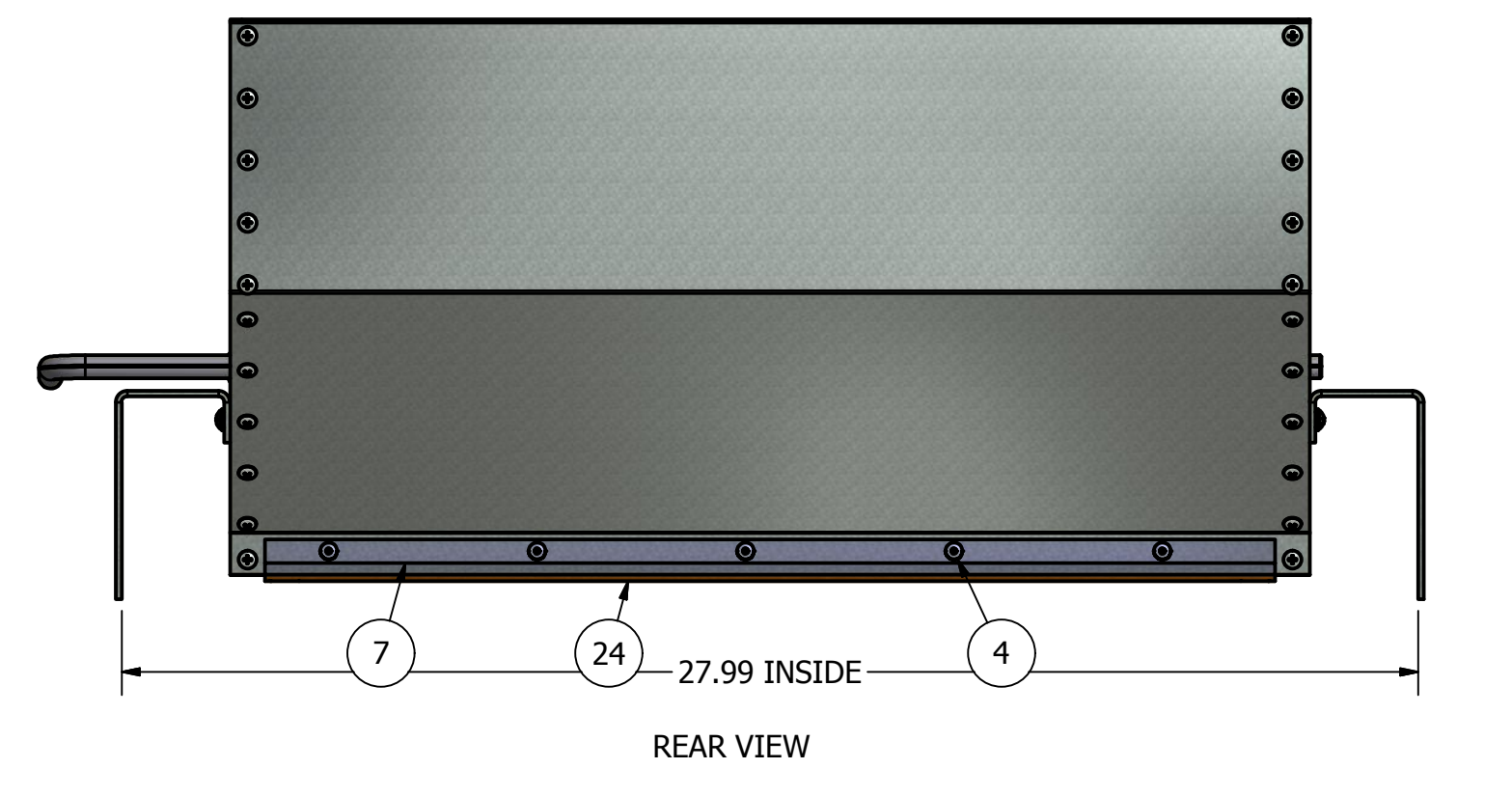
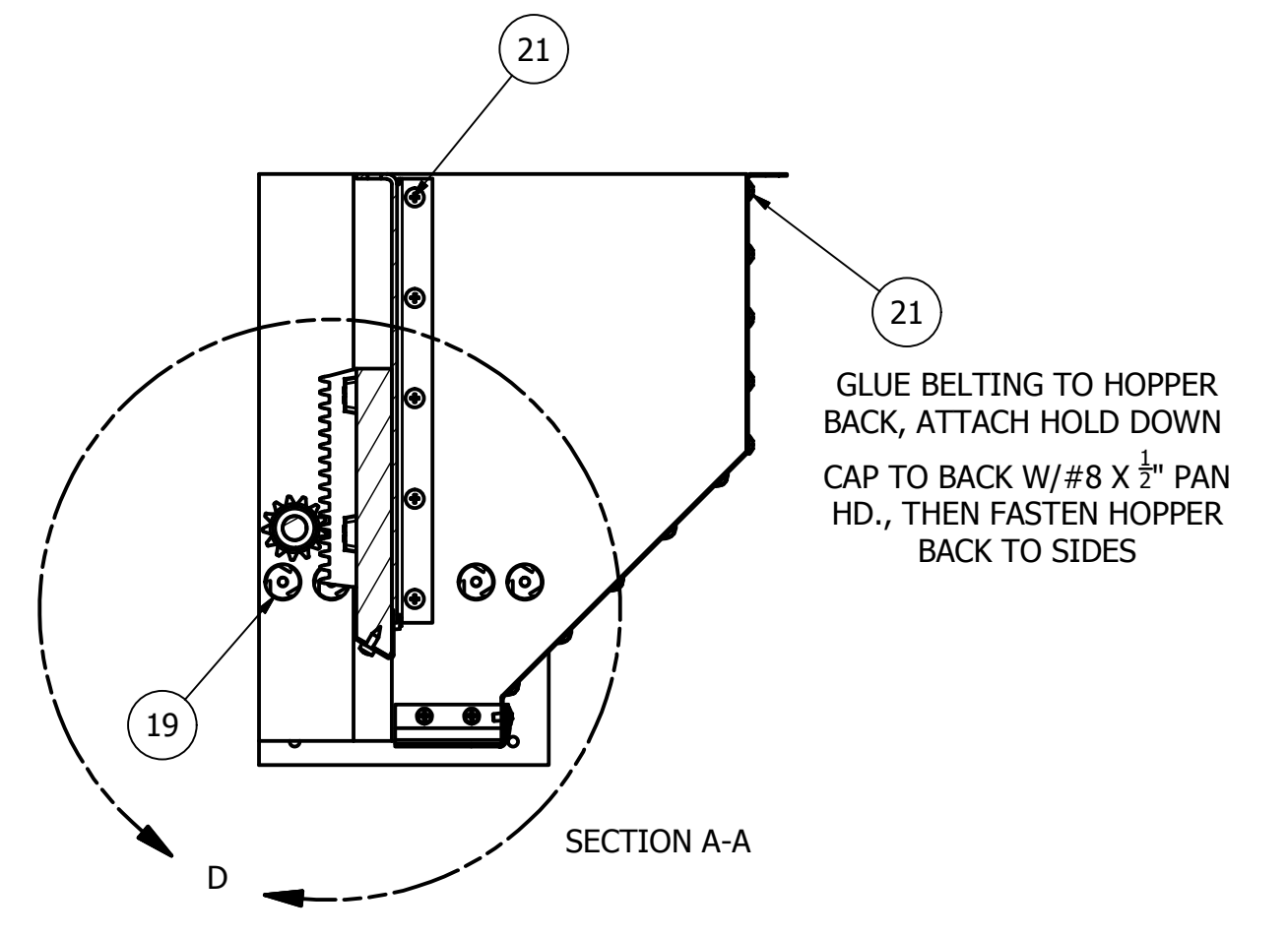
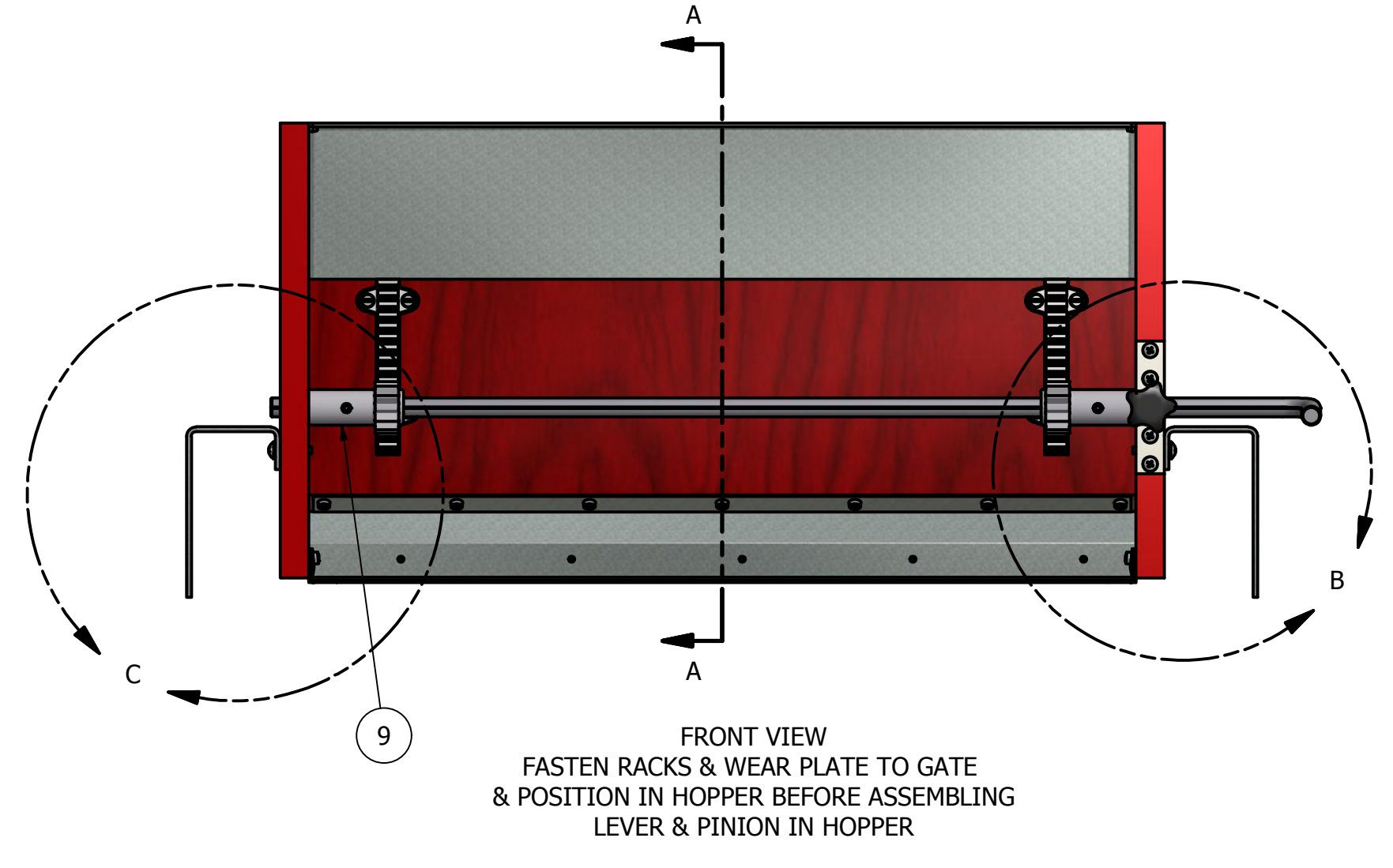
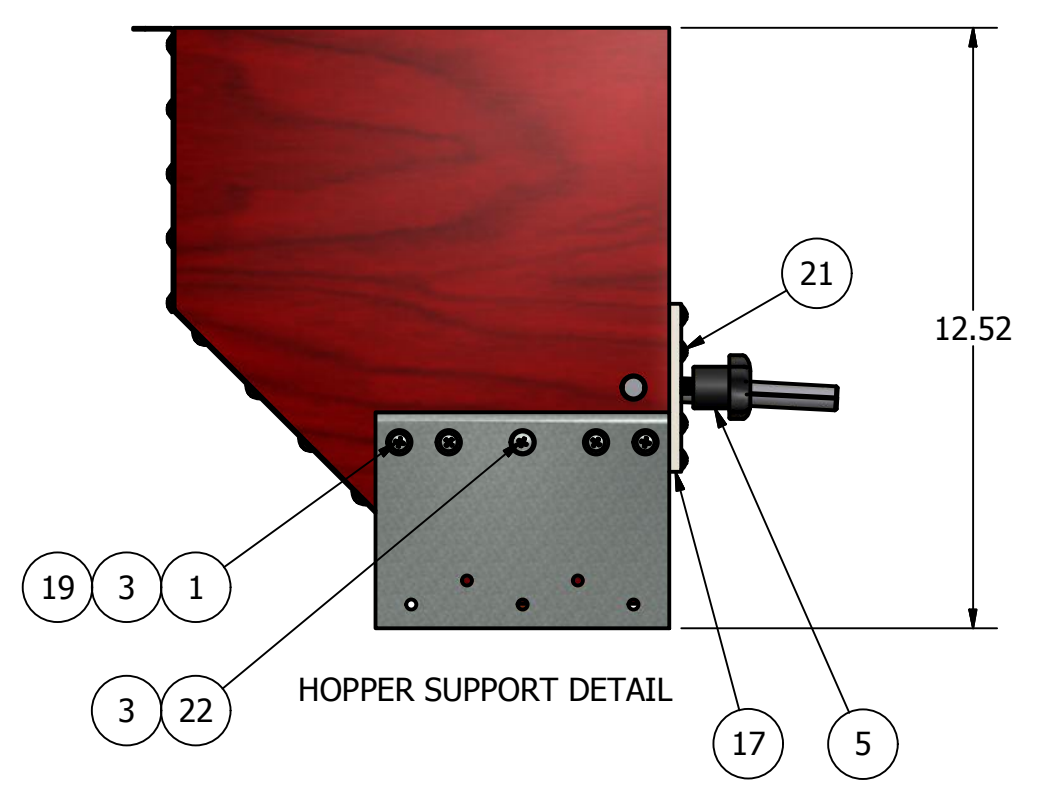
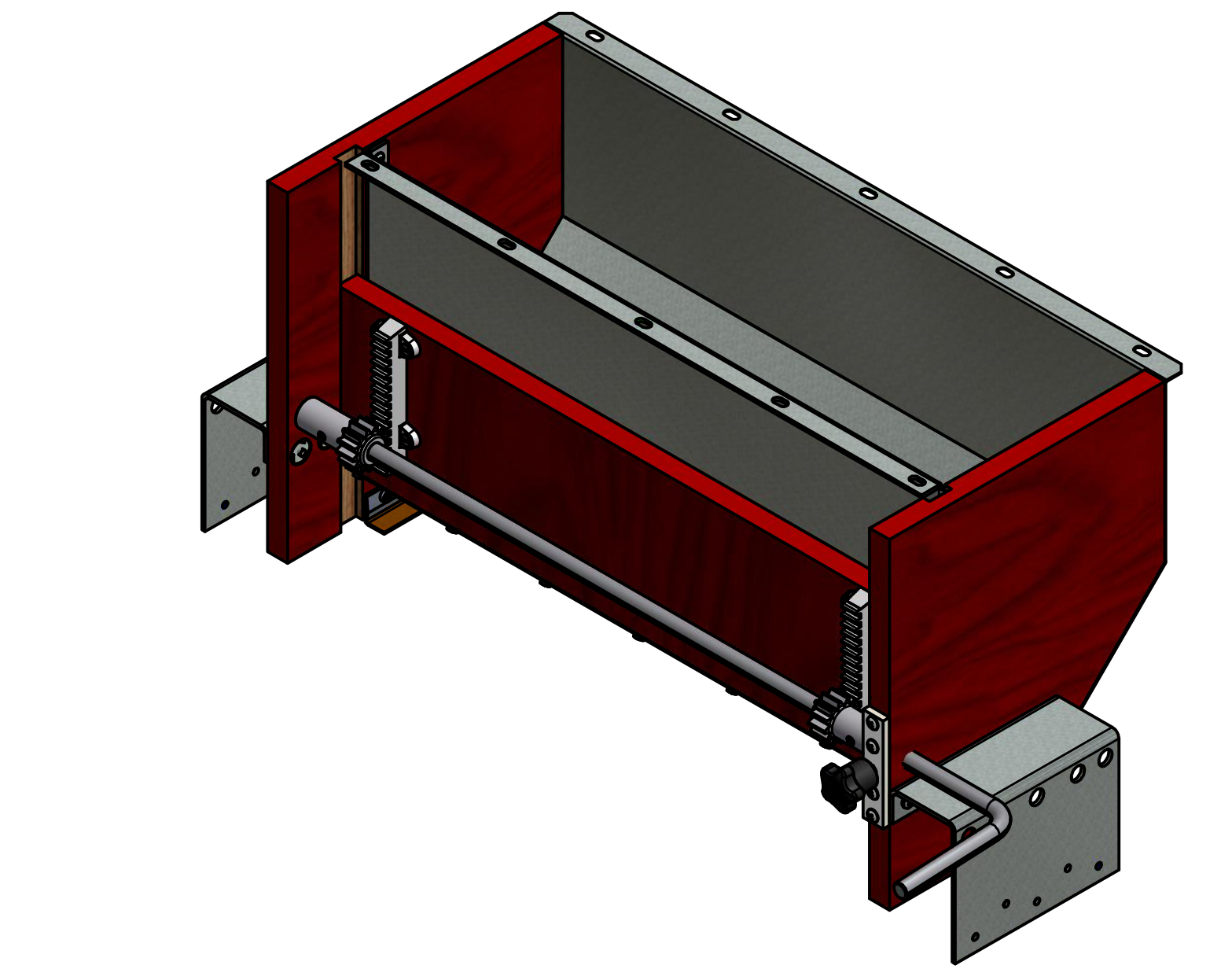
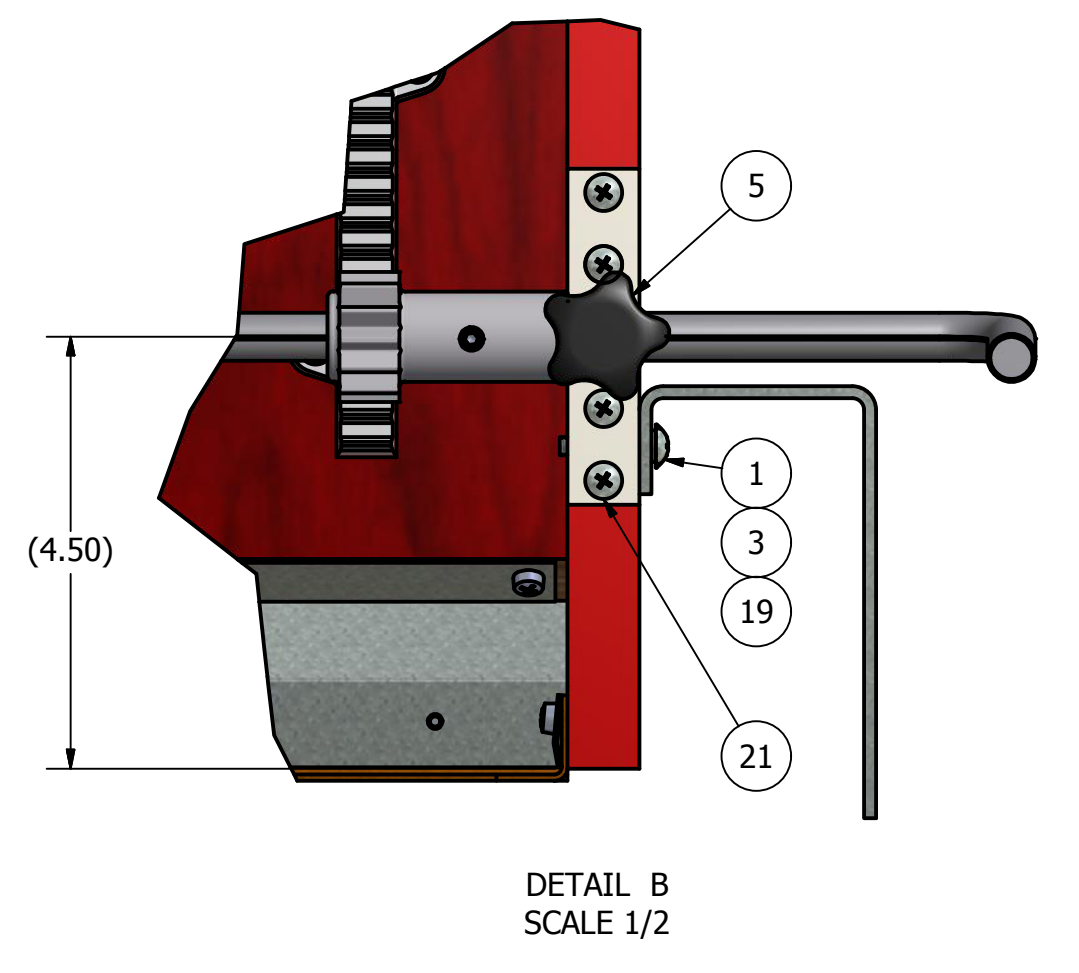
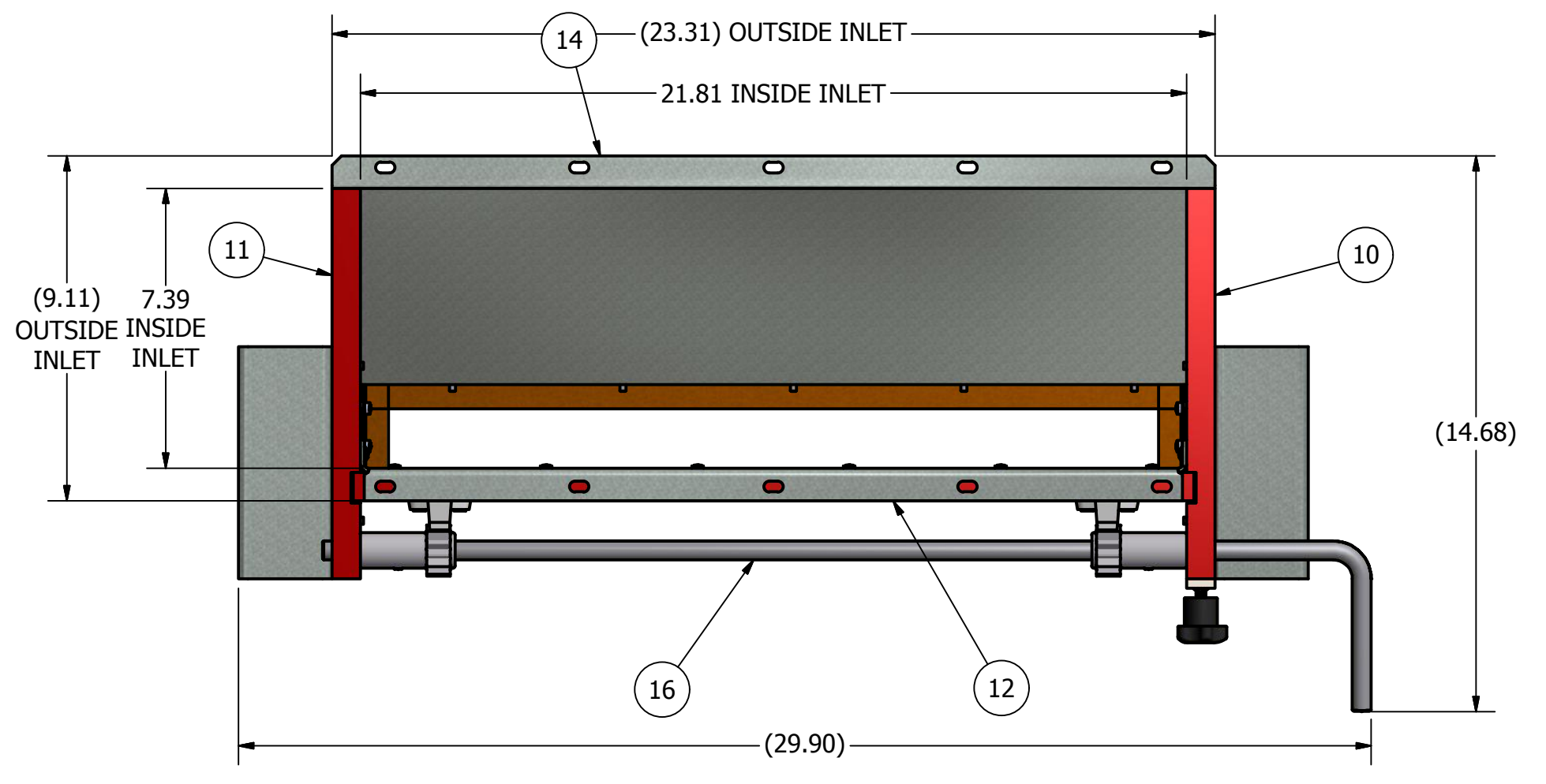
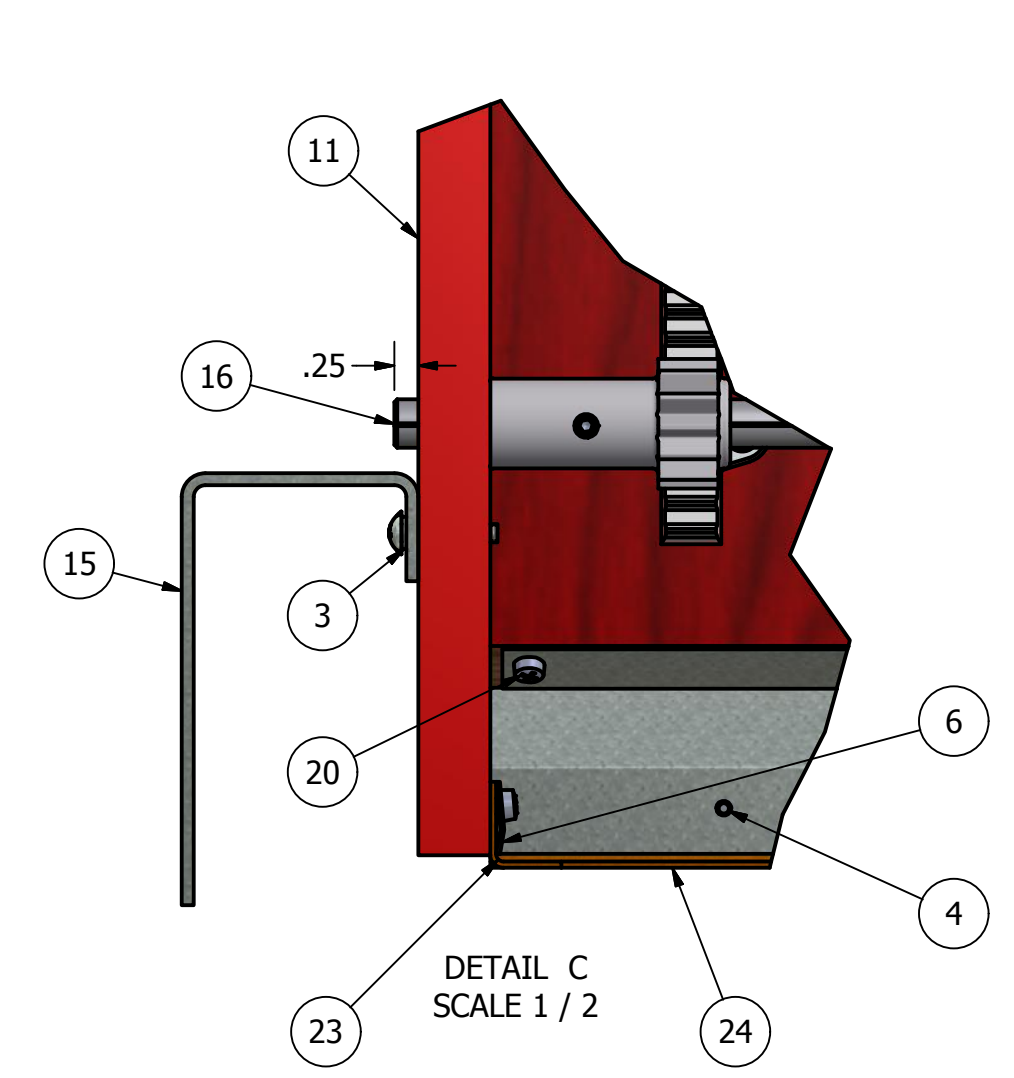

NOTES:
 1. DO NOT SCALE FROM DRAWING.
 2. ONE PIECE REQUIRED PER F60000000: CLEANER ASSY, RH, ECLIPSE 324.

ITEM	PART NUMBER	QTY	DESCRIPTION
24	F91152004	1	BELTING, 3-PLY FSXFS 1.50 X 21.81"
23	F91152004	2	BELTING, 3-PLY FSXFS 1.50 X 2.25"
22	F83453403	2	SMS, PAN X HD, #10 X 3/4"
21	F83453402	36	SMS, PAN X HD, #8 X 3/4"
20	F83451201	17	SMS, PAN X HD, #8 X 1/2"
19	F70010003	8	NUT, T PLATED, 10-24
18	F60003009	1	PLATE, WEAR, HOPPER GATE, ECLIPSE 324
17	F60003008	1	PLATE, LOCK, HOPPER GATE, ECLIPSE
16	F60003007	1	LEVER, HOPPER GATE, ECLIPSE 324
15	F60003006	2	SUPPORT, HOPPER, ECLIPSE 324
14	F60003005	1	BACK, HOPPER, ECLIPSE 324
13	F60003004	1	FRONT, HOPPER, ECLIPSE 324
12	F60003003	1	GATE, HOPPER, ECLIPSE 324
11	F60003002	1	END, LH, INLET HOPPER, ECLIPSE
10	F60003001	1	END, RH, INLET HOPPER, ECLIPSE
9	F04200900	2	PINION, PLAIN HOPPER .50" DIA
8	F04200800	2	RACK, GEAR, IRON, PLAIN HOPPER
7	F03805600	1	RUBBER HOLD-DOWN STRIP, 21.81"
6	F03805600	2	RUBBER HOLD-DOWN STRIP, 2.25"
5	80006003	1	KNOB, 5 ARM POLYPRO, THRD STUD 1/4-20 X 1.00"
4	70007001	5	RIVET, POP SDS54 .156X.13-.38"
3	66442600	10	WASHER, LOCK HELICAL #10
2	65484617	8	SCW, WOOD FLT SLT HD #10 X .75"
1	62342622	8	SCW, MACH, PAN X HEAD, 10-24 X 1.00"

CLIPPER SEPARATION TECHNOLOGIES SINCE 1869

DIVISION OF A.T. FERRELL COMPANY
 1440 S ADAMS ST
 BLUFFTON, INDIANA 46714 - USA
 PH: 260-824-3400
 FAX: 260-824-5463

This drawing is the property of the A. T. Ferrell Company, Inc. and must be returned immediately upon request. No part of this drawing may be reproduced, stored in a retrieval system or transmitted in any form or by any means, without prior written consent of the A. T. Ferrell Company, Inc.

DRAWN BY: jmos
 DRAWN DATE: 6/23/2011
 APPROVED BY: DMJ

TOLERANCES EXCEPT AS NOTED:
 DECIMAL: ± .030
 FRACTIONAL: ± 1/32
 ANGULAR: ± 1/2°

FINISH: NONE

TITLE: HOPPER ASSY, ECLIPSE 324

CAD NO MANUAL CHANGES

SCALE: 1:4
 SHEET: 1 OF 1
 SIZE: D
 PART NUMBER: F60003000
 REV: C