

2

1

REVISION HISTORY				
REV	ECN	DESCRIPTION	DATE	APPROVED
A	K950172	RELEASE PRINT	11/21/1995	DMJOHNSON
B	K070015	70010602(1) WAS F84053502(1)	1/29/2007	DMJOHNSON
C	K070187	REDRAWN INVENTOR	2/4/2008	DMJOHNSON

K100-00206

B

B

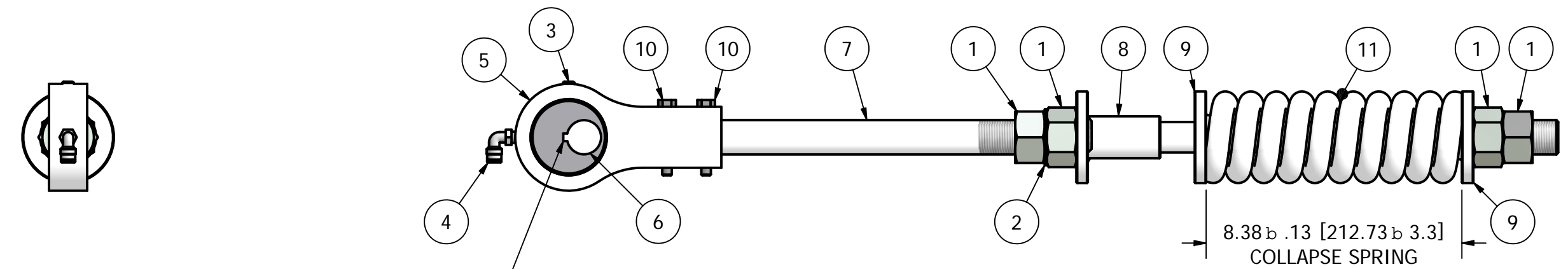

ECCENTRIC SHOWN IN ROLLS CLOSED POSITION

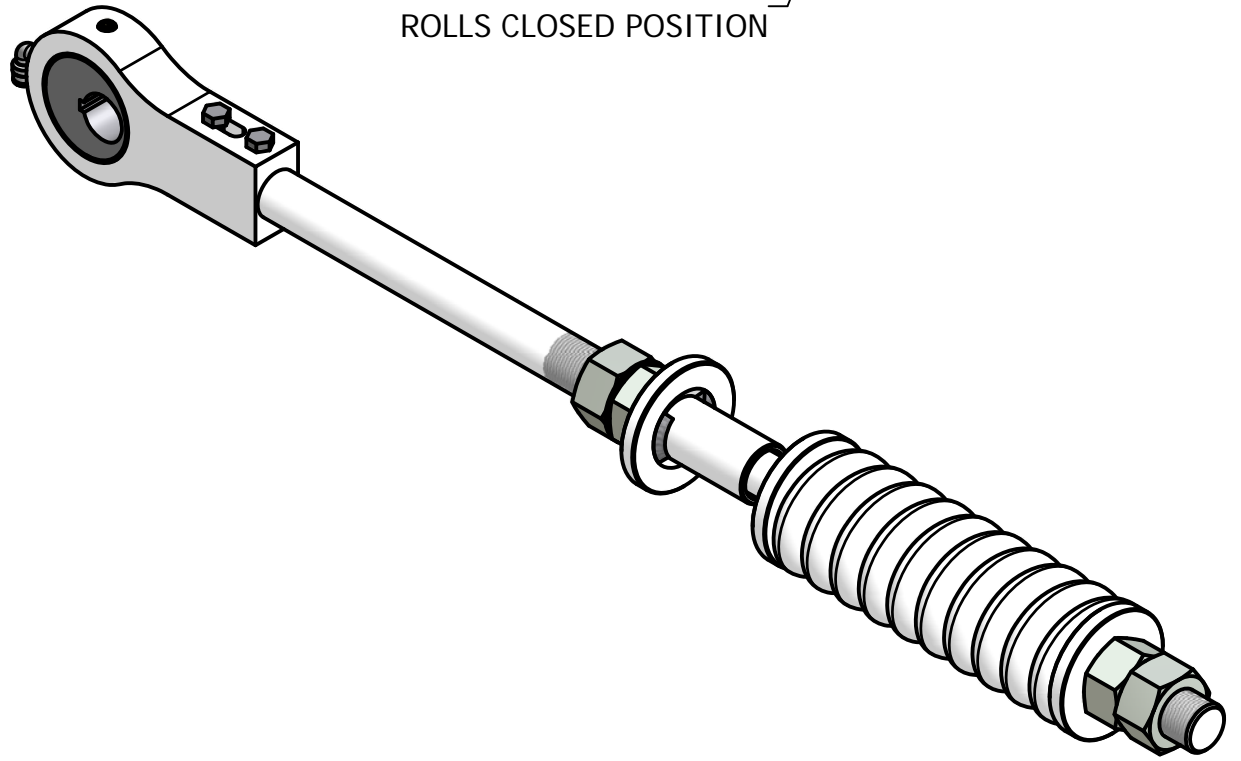

ITEM	PART NUMBER	QTY	DESCRIPTION
11	K201-00275	1	SPRING, ROLL TENSION 9.00" 10-12"
10	K201-00168	2	PIN, SHEAR GD 5 HEX HEAD .313 X 2.25"
9	K200-01642	2	WASHER, SPRING, ROLL TENSION, 10-12"
8	K200-01641	1	WASHER WLDMT, POSITIVE ADJUSTING 10-12"
7	K200-01640	1	ROD, TENSION 10"
6	K200-00952	1	ECCENTRIC, ROLL RELEASE JR
5	K200-00951	1	RING, ECCENTRIC ROLL RELEASE 10"
4	70012050	1	CPLG, ELBOW 90 1/8-27M NPT X 1/4" TBG
3	70010602	1	SCW, SET SKT HD NYLON TIP 3/8-16 X .50"
2	66547800	1	WASHER, LOCK, INTERNAL TOOTH 1.125"
1	66087900	4	NUT, HEX 1.125-12

- NOTES:
- DO NOT SCALE FROM DRAWING.
 - TWO PIECES REQUIRED PER MILL ASSY, SINGLE RH/LH RF/VF 10".
 - FOUR PIECES REQUIRED PER MILL ASSY, 2 HI RH/LH RF/VF 10".
 - ALTERNATIVE DIMENSIONS [X.X] IN MILLIMETERS.

This drawing is the property of the A.T. Ferrell Company, Inc and must be returned immediately upon request. No part of this drawing may be reproduced, stored in a retrieval system or transmitted in any form or by any means, without prior written consent of the A.T. Ferrell Company, Inc	E C F				
	NO MANUAL CHANGES				
	VQNGT CP E GU EXCEPT AS NOTED		DIVISION OF A. T. FERRELL COMPANY		
	DECIMAL: xxx ± .005 xx ± .030	FINISH:	SCALE: 1:4	DRAWN BY: dmjohnson	APPROVED BY: DMJ
	FRACTIONAL: ± 1/32	TITLE: ROLL TENSION ASSY, SPRING 10"			
ANGULAR: ± 1/2~	DATE: 1/12/2008	SIZE: B	PART NUMBER: K100-00206	SHEET: 1 of 1	

2

1

