

# M-2B and NO. 27 FARM SIZE CLEANERS

Each cleaner can be equipped with a self-contained slurry treater as shown.

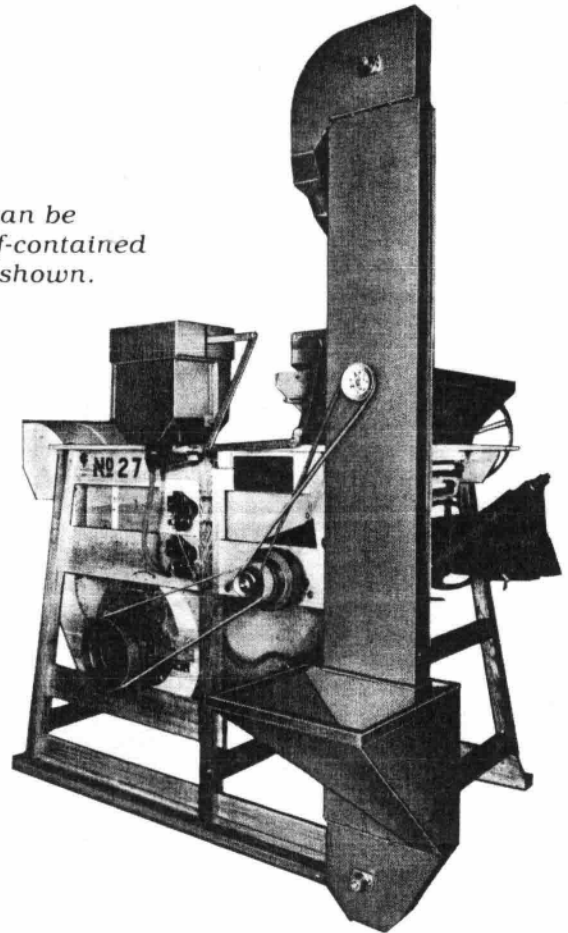
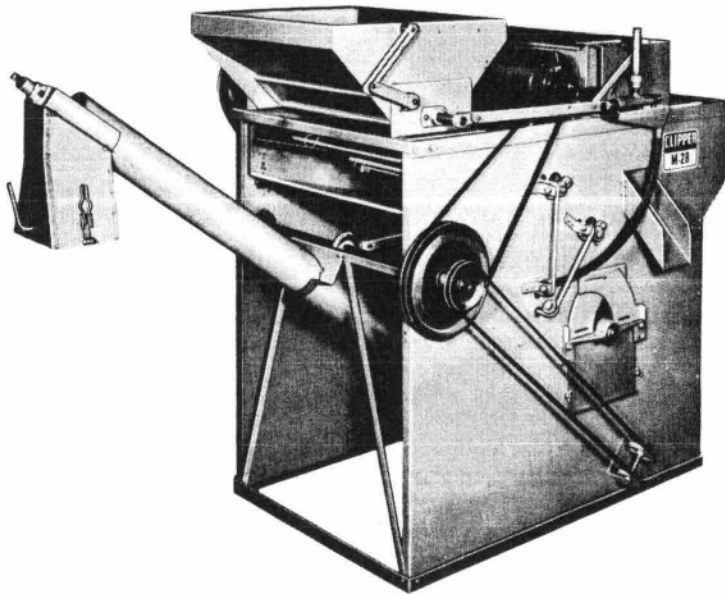

## CLIPPER FARM SIZE CLEANERS — M-2B and No. 27

Both two-screen models do identical cleaning . . . but at different capacities . . . with numerous applications in addition to farm use.

Clipper M-2B with treater, bagging auger and control feed hopper.

Clean • Treat • Elevate • Rough scalp up to 40 bushels per hour.

Clipper No. 27 with treater, vertical elevator, bagging auger, control feed hopper and sink hopper.

Clean • Treat • Elevate • Rough scalp up to 100 bushels per hour.

All capacities will vary according to area and amount of foreign material in the commodity to be cleaned.

### FARM MODEL SPECIFICATIONS

	M-2B		No. 27	
	Basic Machine	Complete As Shown	Basic Machine with Roll Feed Hopper	Complete As Shown
Screen Size	24½" x 22¼"	24½" x 22¼"	34" x 42"	34" x 42"
No. Screens in Cleaner	2	2	2	2
No. Screens Furnished	8	8	6	6
Extreme Height	50"	50"	71"	102"
Extreme Length	54"	77½"	74"	87"
Extreme Width	38"	38"	48"	66"
Horsepower Required	½	½	1	1
Shipping Weights (lbs.) Including Guards	480	560	1020	1250

Width specifications listed above do not include dimensions for modular guards. A complete list of attachment kits is available with current prices and approximate shipping weights.

## COMMODITY FLOW

The commodity is fed to the hopper which spreads it evenly across the full width of the top screen. The top screen perforation is selected with openings larger than the product being cleaned to scalp off large foreign material ① while the good commodity falls through. The bottom screen is selected with openings smaller than the commodity being cleaned, passing the good product over this second screen ②. Trash, weed seeds and splits drop through ③. After screening, the product is routed through the air column of the bottom blast fan to remove any remaining lightweight trash and dust ④ that was missed during the process. This air separation is very selective. The fan speed is controlled by means of a 3-step pulley arrangement and adjustable air intake slides provide for intermediate settings. Good, clean product is discharged ⑤.

## TREATING

Both the M-2B and No. 27 can be equipped with a self-contained slurry treater. The slurry treater is simply a dispensing unit. It meters wettable powder or liquid treating agents by means of a piston driven from a rotating shaft in the hopper. A rubber hose routes the liquid to the lower end of the bagging or wagon-box auger where the actual mixing of the seed and the liquid takes place. An auger is mandatory when treating.

When a slurry treater is used on an M-2B, the cleaner must also be equipped with brushes and a control feed hopper.

## ELEVATING

The bagging auger elevates to a convenient sack height. A 14-foot auger with adapter and drive is available to elevate the cleaned-treated commodity to truck bed, wagon box or bin. It is driven from the cleaner and discharges at a height of 8 feet. When a 14-foot auger is used on a No. 27, two-piece screens must be used in the cleaner.

## M-2B FEATURES

The all-steel M-2B is available with or without screen cleaning brushes. Brushes, however, are recommended for faster and more thorough cleaning.

This small cleaner is designed especially for farm use, supplying up to 40 bushels per hour capacity when rough scalping. Because of its size and reliability, the M-2B has been favorably accepted for educational groups . . . in canneries for pea grading . . . foundation seed work . . . and in seed processing plants for small lots and salvage work. This cleaner has been used successfully in many non-agricultural sizing and grading operations. It is a compact, sturdy machine equipped with ball bearings and V-belt drives, constructed to perform with minimum maintenance.

Standard equipment for the M-2B includes a gravity hopper. When this hopper is used, the cleaner is equipped with an agitator wire attached to the shoe and extending into the hopper, moving material to the gate opening.

## No. 27 FEATURES

The all hardwood constructed No.27 is a quality machine. Bottom screen cleaning brushes are standard

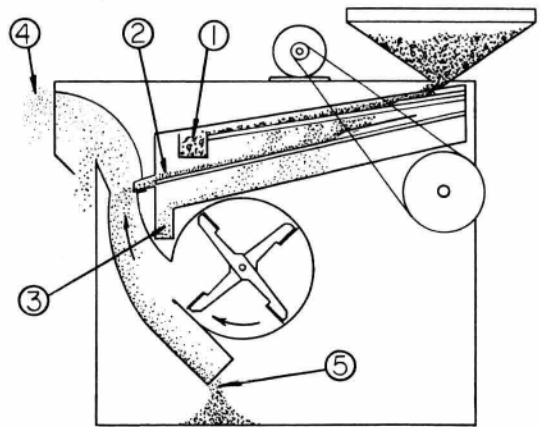

equipment . . . top screen brushes are optional. The product being cleaned and the bottom screen opening are close to the same size, necessitating brushes to keep the screen free from clogging.

The No. 27 is big enough for small scale commercial operations, supplying up to 100 bushels per hour when rough scalping. If the machine is used for cleaning certified seed, it must be equipped with top screen brushes as well as the furnished bottom brushes. This cleaner has been suitably used for foundation seed work at lesser capacities. When the No. 27 is equipped as illustrated, it becomes a self-contained unit and lends itself for use as a portable installation. This cleaner is especially good for seasonal work. It can be easily moved aside when not in use . . . a feature not possible with a permanent installation.

Two-piece screens . . . essential when a 14-foot auger is used . . . can be supplied upon request. In difficult and compound separations, these screens can be made using one perforation on the upper half and another one on the lower section. Special hoppers are available to handle certain commodities. A variable speed fan drive can be supplied at additional cost in place of the 3-step pulleys, permitting air adjustments to be made while the cleaner is in operation.

## COMMON FEATURES

The brushes on these cleaners are adjustable and the screens can be quickly pulled and replaced. Over 200 different screen sizes are available in perforated metal and wire cloth for all cleaning/grading requirements.

Modular guards are included on both cleaners as standard equipment to meet more stringent requirements for operator protection. They are built in sections of expanded metal . . . construction enables easy access for making adjustments to the cleaners and commodity sampling.

