

REVISION HISTORY			
REV	ECN	DESCRIPTION	DATE
A	F010001	RELEASE	4/25/2001
B	F080035	66783300(10) WAS 66083300(10), 66403300(10) & 66443300(10); 80014003(6) WAS 80014007(12); ADD SHEETS 2-4	3/31/2008

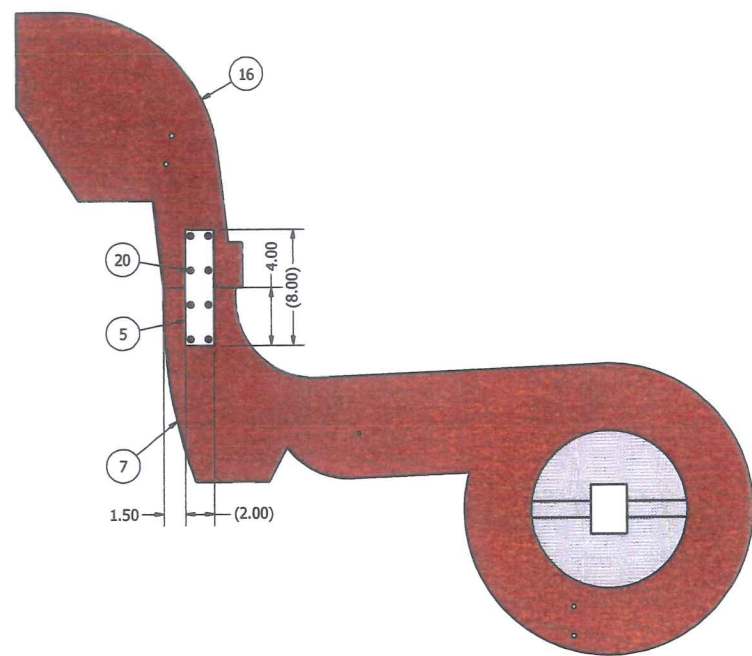

STEP #1-LEFT SIDE ASSEMBLY

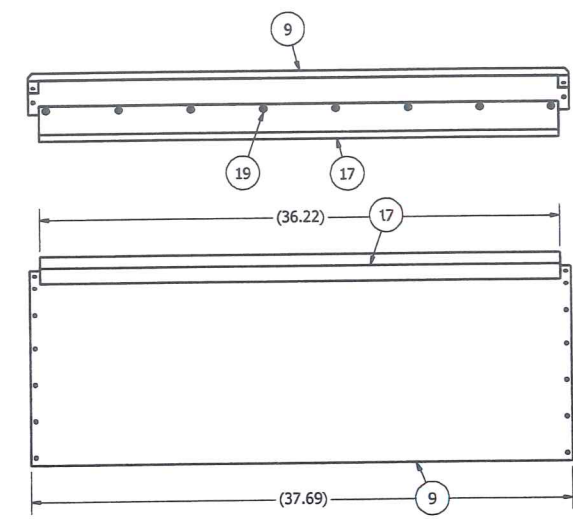
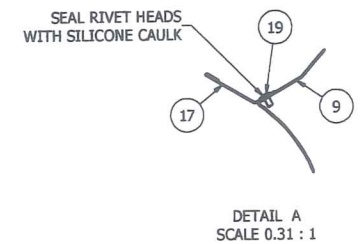
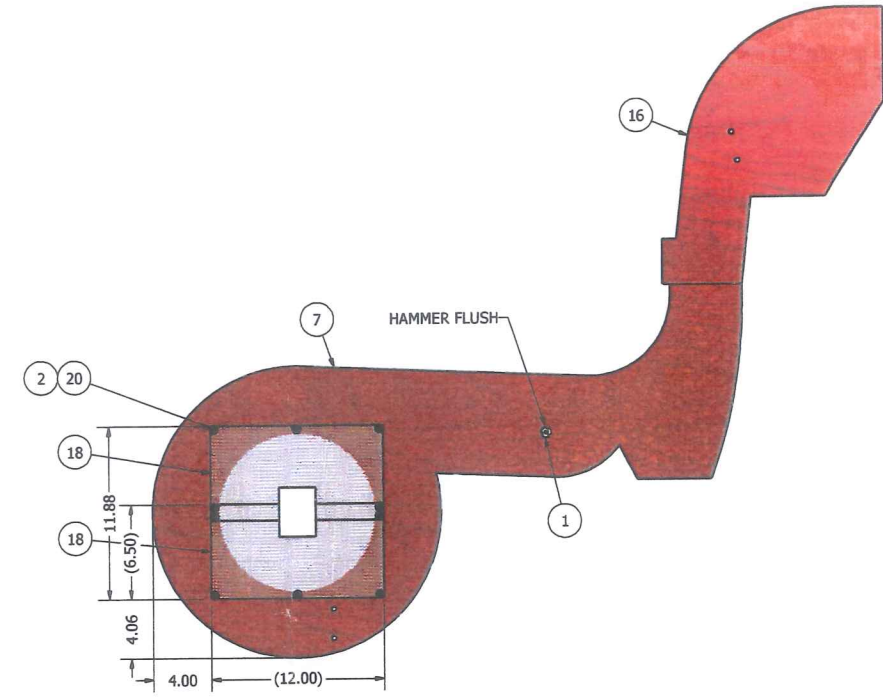
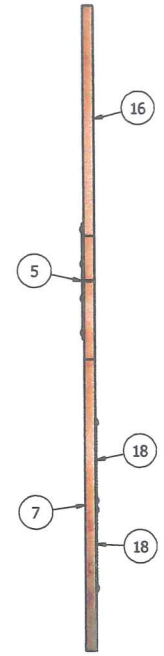

STEP #2-LOWER WRAPPER ASSEMBLY

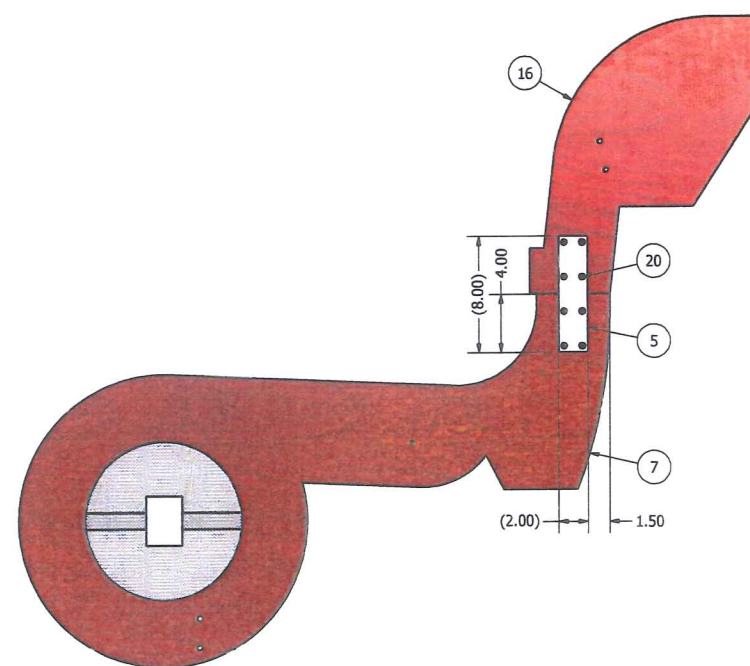

STEP #1-RIGHT SIDE ASSEMBLY

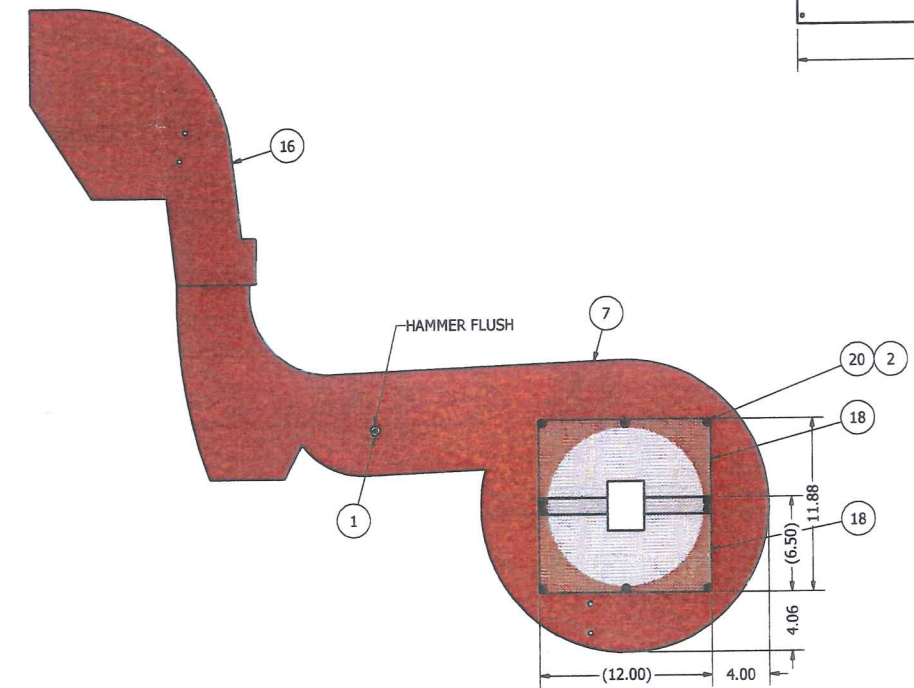
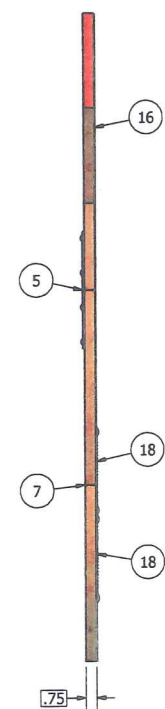

20	F83453402	140	SMS, PHP PAN HD #8 X 3/4"
19	F83200011	8	RIVET, POP SDS64 .188X.125-.250
18	F61003099	4	GUARD, INLET, BTM FAN, CONQUEST
17	F60002118	1	DEFLECTOR, AIR, FAN HSG, ECLIPSE 334
16	F60002117	2	SIDE, HOOD, FAN HOUSING, ECLIPSE 334
15	F60002115	1	WRAPPER, LOWER, FAN SCROLL, ECLIPSE 334
14	F60002113	2	CATCHALL ASSY, ECLIPSE 334
13	F60002112	1	WRAPPER, UPPER, FAN HOOD, ECLIPSE 334
12	F60002111	1	WRAPPER, LOWER, FAN HOOD, ECLIPSE 334
11	F60002110	1	WRAPPER, REAR, FAN TRANS, ECLIPSE 334
10	F60002109	1	HATCH, FAN HOUSING, ECLIPSE 334
9	F60002108	1	WRAPPER, LOWER, FAN TRANS, ECLIPSE 334
8	F60002107	1	WRAPPER, UPPER, FAN SCROLL, ECLIPSE 334
7	F60002105	2	SIDE, FAN HOUSING, ECLIPSE 334
6	F60002101	1	FAN WHEEL ASSY, ECLIPSE 334
5	F07303500	2	IRON, STRAP, SETTLING CHAMBER 2 X 8"
4	80014003	2	TAPE, POLYURETHANE, 3/4 X 5/16 X 36.00"
3	66783300	10	NUT, HEX SERR LOCK 1/4-20
2	66402200	20	WASHER, FLAT #8
1	66383300	2	NUT, T 1/4-20 PLT

ITEM	PART NUMBER	QTY	DESCRIPTION
<p>This drawing is the property of the A.T. Ferrell Company, Inc and must be returned immediately upon request. No part of this drawing may be reproduced, stored in a retrieval system or transmitted in any form or by any means, without prior written consent of the A.T. Ferrell Company, Inc</p>			
<p>CAD NO MANUAL CHANGES TOLERANCES EXCEPT AS NOTED</p>			
DIVISION OF A. T. FERRELL COMPANY BLUFFTON, INDIANA - USA		SCALE: 0.16:1 DRAWN BY: dmjohnson APPROVED BY: DMJ	
TITLE: HOUSING ASSY, FAN, ECLIPSE 334 DATE: 3/20/2008 SIZE: D PART NUMBER: F60002100 SHEET: 1 of 4			

NOTES:
 1. DO NOT SCALE FROM DRAWING.
 2. ONE PIECE REQUIRED PER F60000100: CLEANER ASSY, ECLIPSE 334.

REVISION HISTORY			
REV	ECN	DESCRIPTION	DATE
A	F010001	RELEASE	4/25/2001
B	F080035	66783300(10) WAS 66083300(10), 66403300(10) & 66443300(10); 80014003(6) WAS 80014007(12); ADD SHEETS 2-4	3/31/2008

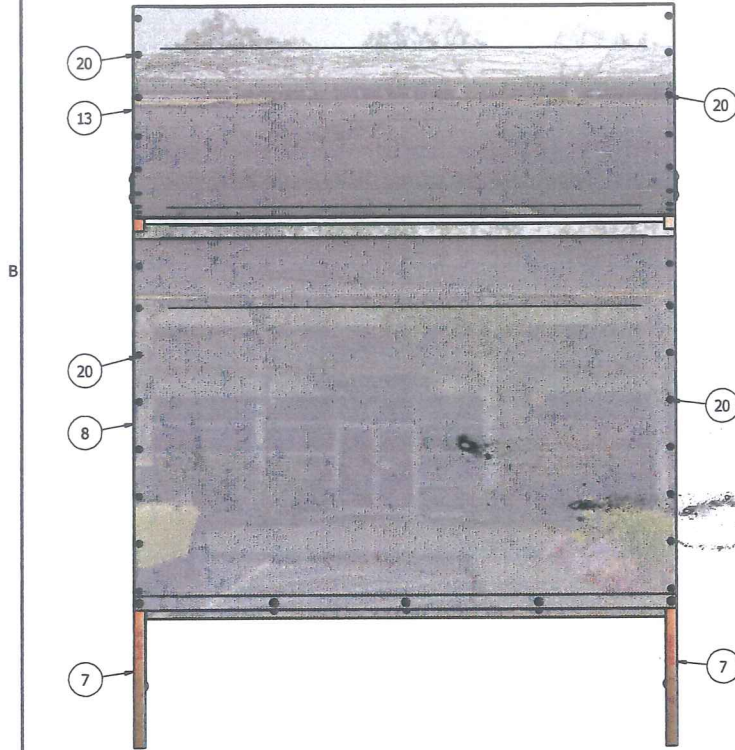

STEP #4 UPPER WRAPPER INSTALLATION, TOP VIEW

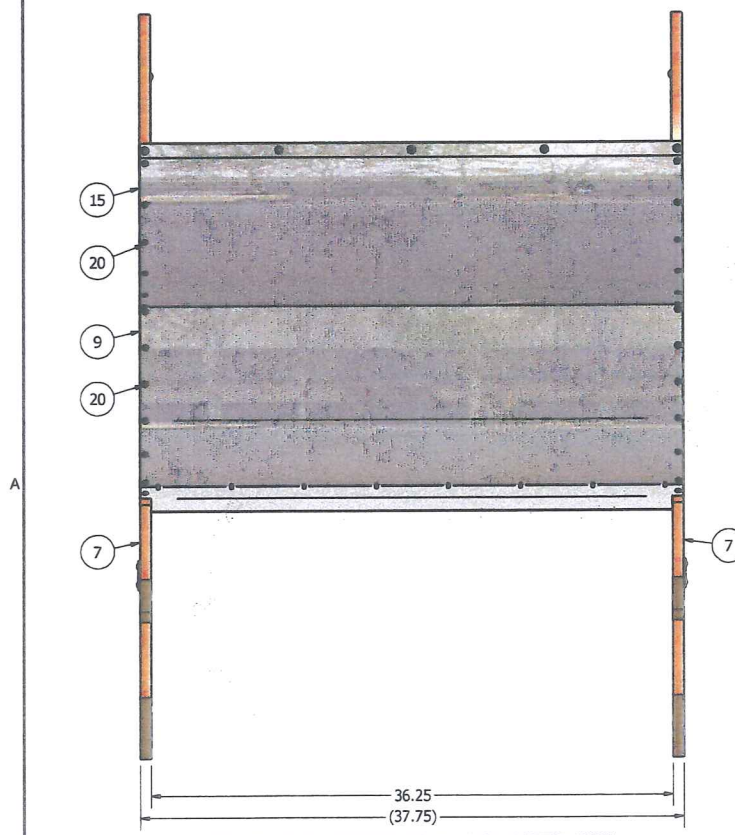

STEP #3-LOWER WRAPPER INSTALLATION, BOTTOM VIEW

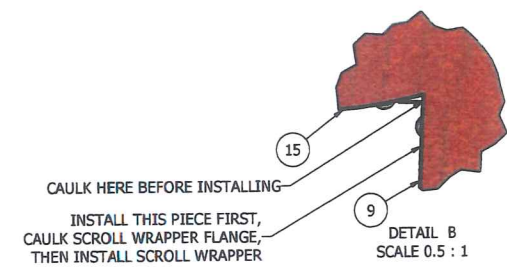
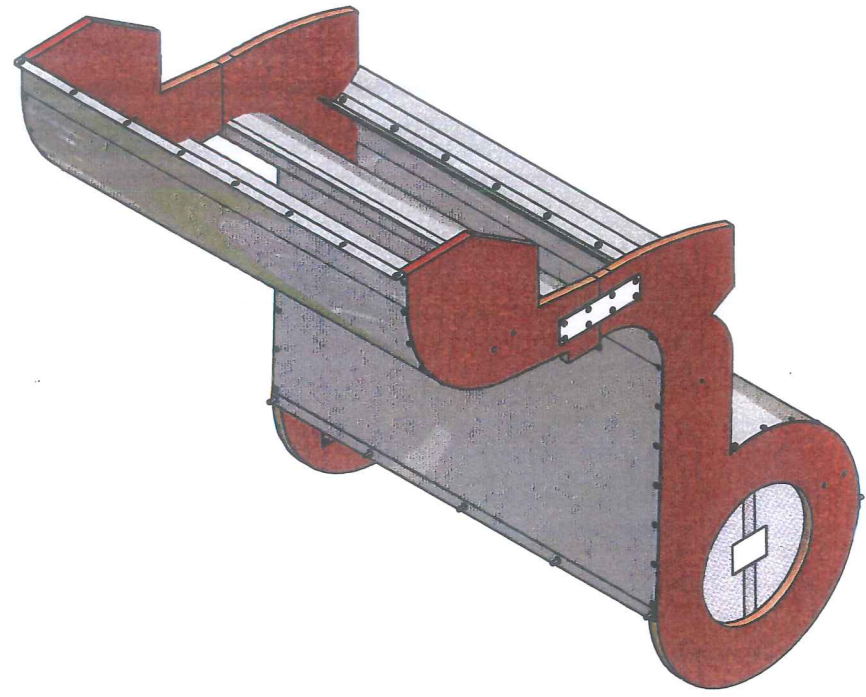
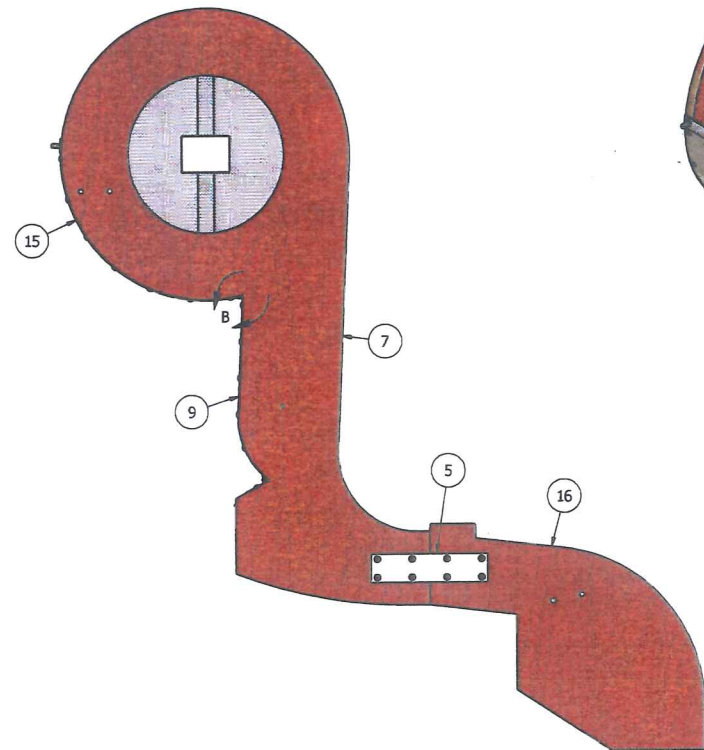
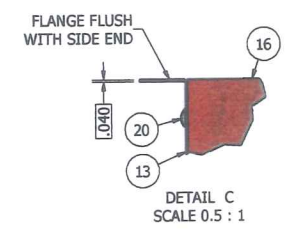
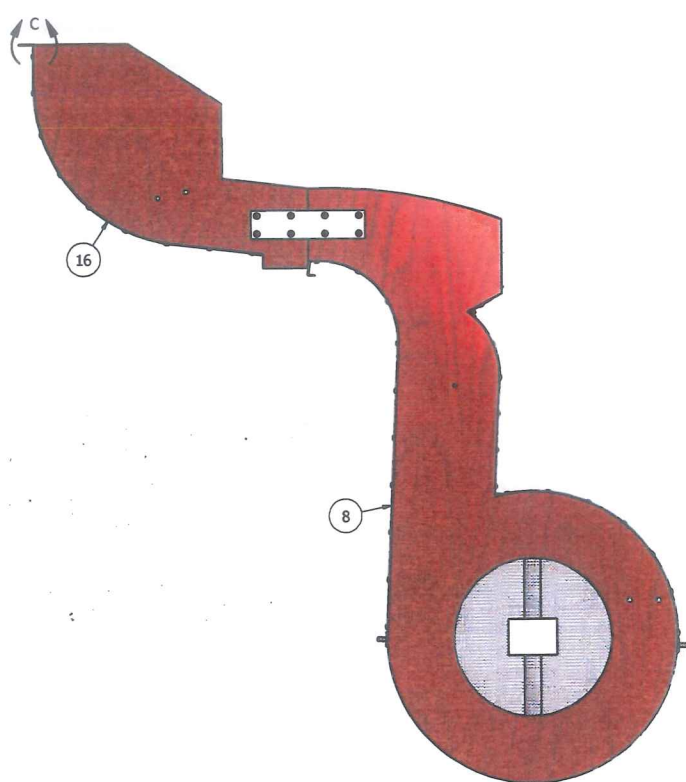

ITEM	PART NUMBER	QTY	DESCRIPTION
20	F83453402	140	SMS, PHP PAN HD #8 X 3/4"
19	F83200011	8	RIVET, POP SDS64 .188X.125-.250
18	F61003099	4	GUARD, INLET, BTM FAN, CONQUEST
17	F60002118	1	DEFLECTOR, AIR, FAN HSG, ECLIPSE 334
16	F60002117	2	SIDE, HOOD, FAN HOUSING, ECLIPSE 334
15	F60002115	1	WRAPPER, LOWER, FAN SCROLL, ECLIPSE 334
14	F60002113	2	CATCHALL ASSY, ECLIPSE 334
13	F60002112	1	WRAPPER, UPPER, FAN HOOD, ECLIPSE 334
12	F60002111	1	WRAPPER, LOWER, FAN HOOD, ECLIPSE 334
11	F60002110	1	WRAPPER, REAR, FAN TRANS, ECLIPSE 334
10	F60002109	1	HATCH, FAN HOUSING, ECLIPSE 334
9	F60002108	1	WRAPPER, LOWER, FAN TRANS, ECLIPSE 334
8	F60002107	1	WRAPPER, UPPER, FAN SCROLL, ECLIPSE 334
7	F60002105	2	SIDE, FAN HOUSING, ECLIPSE 334
6	F60002101	1	FAN WHEEL ASSY, ECLIPSE 334
5	F07303500	2	IRON, STRAP, SETTLING CHAMBER 2 X 8"
4	80014003	2	TAPE, POLYURETHANE, 3/4 X 5/16 X 36.00"
3	66783300	10	NUT, HEX SERR LOCK 1/4-20
2	66402200	20	WASHER, FLAT #8
1	66383300	2	NUT, T 1/4-20 PLT

NOTES:
 1. DO NOT SCALE FROM DRAWING.
 2. ONE PIECE REQUIRED PER F60000100: CLEANER ASSY, ECLIPSE 334.

This drawing is the property of the A.T. Ferrell Company, Inc. and must be returned immediately upon request. No part of this drawing may be reproduced, stored in a retrieval system or transmitted in any form or by any means, without prior written consent of the A.T. Ferrell Company, Inc.

CAD
 NO MANUAL CHANGES
 TOLERANCES EXCEPT AS NOTED

FINISH: NONE
 SCALE: 0.16:1
 DRAWN BY: dmjohnson
 APPROVED BY: DMJ

TITLE: HOUSING ASSY, FAN, ECLIPSE 334
 DATE: 3/20/2008
 SIZE: D
 PART NUMBER: F60002100
 SHEET: 2 of 4

DIVISION OF A. T. FERRELL COMPANY
 BLUFFTON, INDIANA - USA

REVISION HISTORY			
REV	ECN	DESCRIPTION	DATE
A	F010001	RELEASE	4/25/2001
B	F080035	66783300(10) WAS 66083300(10), 66403300(10) & 66443300(10); 80014003(6) WAS 80014007(12)"; ADD SHEETS 2-4	3/31/2008

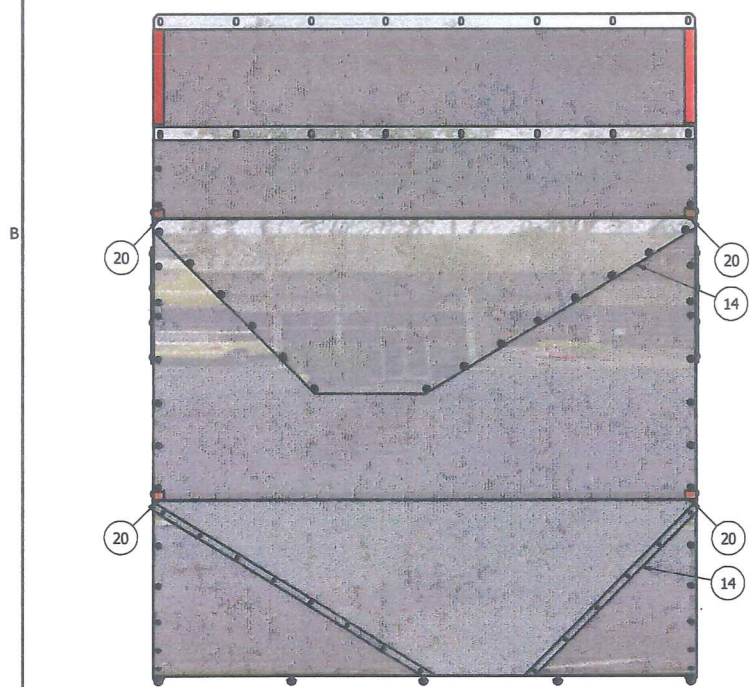

STEP #6-CATCHALL INSTALLATION, REAR VIEW

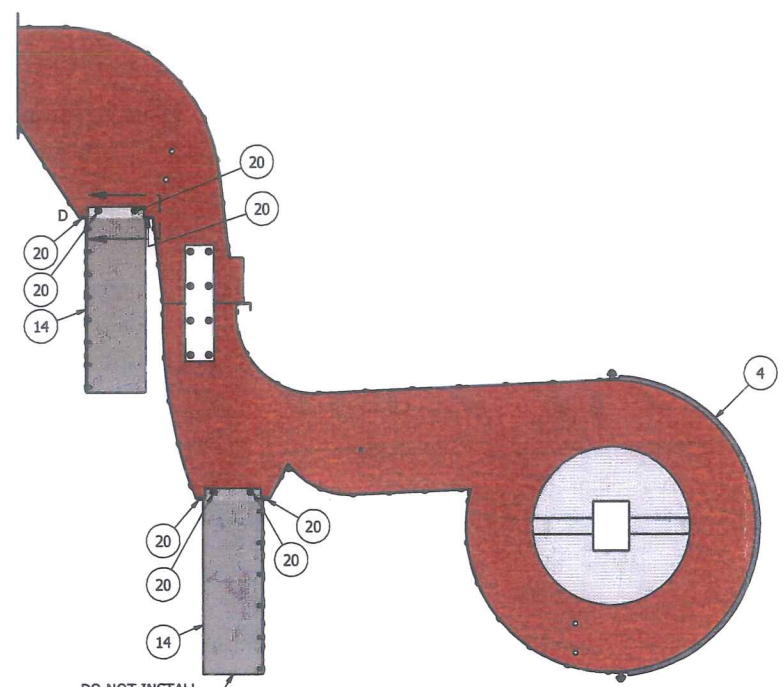

DO NOT INSTALL,
 LOCATE SPOUT & PRE-DRILL
 Ø1/8 SCREW HOLES

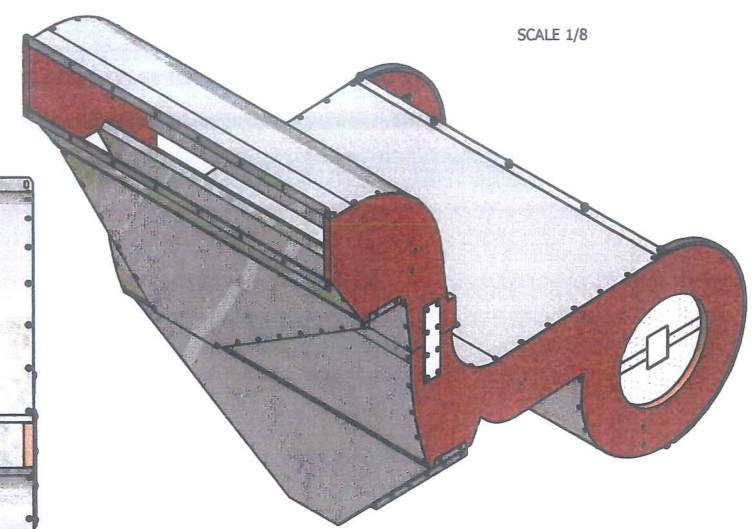

SCALE 1/8

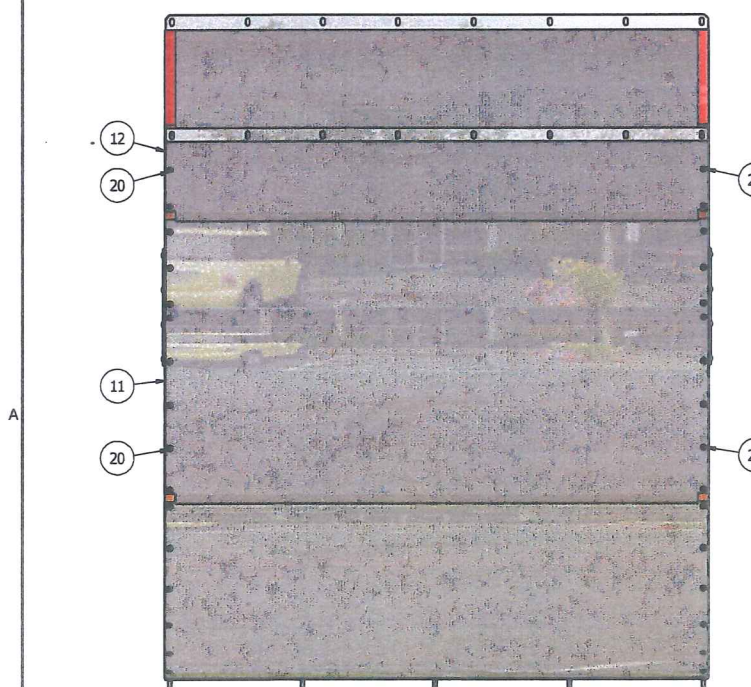

STEP #5-REAR WRAPPER INSTALLATION, REAR VIEW

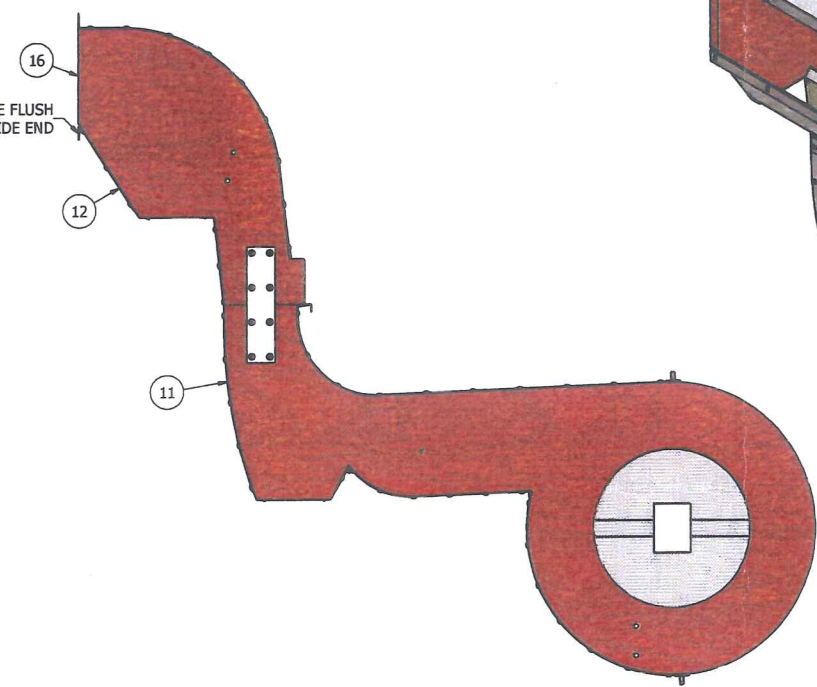

FLANGE FLUSH
 WITH SIDE END

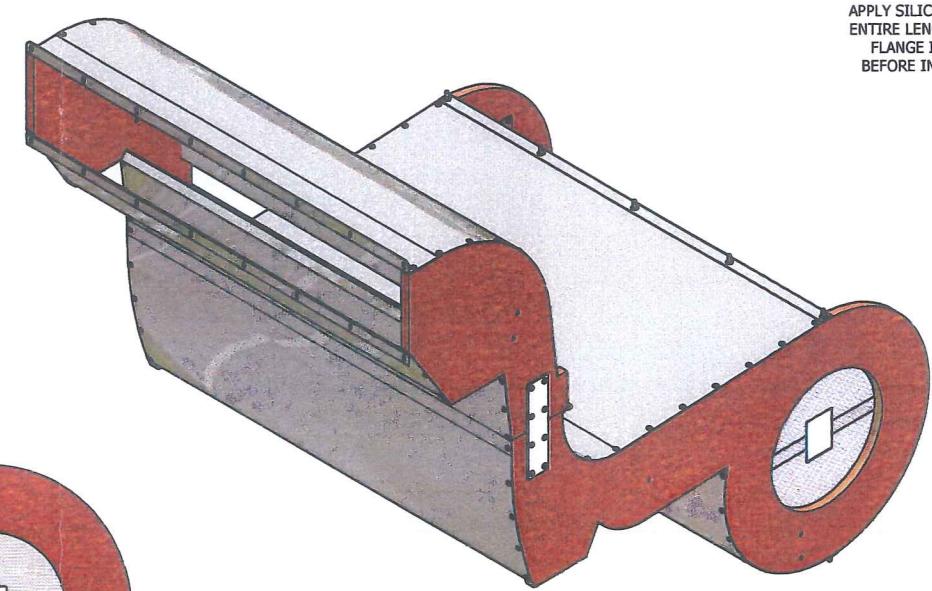

DETAIL D
 SCALE 1 / 2

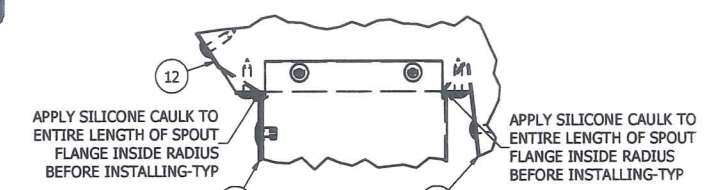

APPLY SILICONE CAULK TO
 ENTIRE LENGTH OF SPOUT
 FLANGE INSIDE RADIUS
 BEFORE INSTALLING-TYP

ITEM	PART NUMBER	QTY	DESCRIPTION
20	F83453402	140	SMS, PHP PAN HD #8 X 3/4"
19	F83200011	8	RIVET, POP SDS64 .188X.125-.250
18	F61003099	4	GUARD, INLET, BTM FAN, CONQUEST
17	F60002118	1	DEFLECTOR, AIR, FAN HSG, ECLIPSE 334
16	F60002117	2	SIDE, HOOD, FAN HOUSING, ECLIPSE 334
15	F60002115	1	WRAPPER, LOWER, FAN SCROLL, ECLIPSE 334
14	F60002113	2	CATCHALL ASSY, ECLIPSE 334
13	F60002112	1	WRAPPER, UPPER, FAN HOOD, ECLIPSE 334
12	F60002111	1	WRAPPER, LOWER, FAN HOOD, ECLIPSE 334
11	F60002110	1	WRAPPER, REAR, FAN TRANS, ECLIPSE 334
10	F60002109	1	HATCH, FAN HOUSING, ECLIPSE 334
9	F60002108	1	WRAPPER, LOWER, FAN TRANS, ECLIPSE 334
8	F60002107	1	WRAPPER, UPPER, FAN SCROLL, ECLIPSE 334
7	F60002105	2	SIDE, FAN HOUSING, ECLIPSE 334
6	F60002101	1	FAN WHEEL ASSY, ECLIPSE 334
5	F07303500	2	IRON, STRAP, SETTLING CHAMBER 2 X 8"
4	80014003	2	TAPE, POLYURETHANE, 3/4 X 5/16 X 36.00"
3	66783300	10	NUT, HEX SERR LOCK 1/4-20
2	66402200	20	WASHER, FLAT #8
1	66383300	2	NUT, T 1/4-20 PLT

NOTES:
 1. DO NOT SCALE FROM DRAWING.
 2. ONE PIECE REQUIRED PER F60000100: CLEANER ASSY, ECLIPSE 334.

This drawing is the property of the A.T. Ferrell Company, Inc and must be returned immediately upon request. No part of this drawing may be reproduced, stored in a retrieval system or transmitted in any form or by any means, without prior written consent of the A.T. Ferrell Company, Inc.

CAD
 NO MANUAL CHANGES
 TOLERANCES EXCEPT AS NOTED

DECIMAL: ± .005
 FRACTIONAL: ± 1/32
 ANGULAR: ± 1/2'

DIVISION OF A. T. FERRELL COMPANY
 FINISH: NONE
 SCALE: 0.16:1
 DRAWN BY: dmjohnson
 APPROVED BY: DMJ

TITLE: HOUSING ASSY, FAN, ECLIPSE 334
 DATE: 3/20/2008
 SIZE: D
 PART NUMBER: F60002100
 SHEET: 3 of 4

REVISION HISTORY			
REV	ECN	DESCRIPTION	DATE
A	F010001	RELEASE	4/25/2001
B	F080035	66783300(10) WAS 66083300(10), 66403300(10) & 66443300(10); 80014003(6) WAS 80014007(12); ADD SHEETS 2-4	3/31/2008

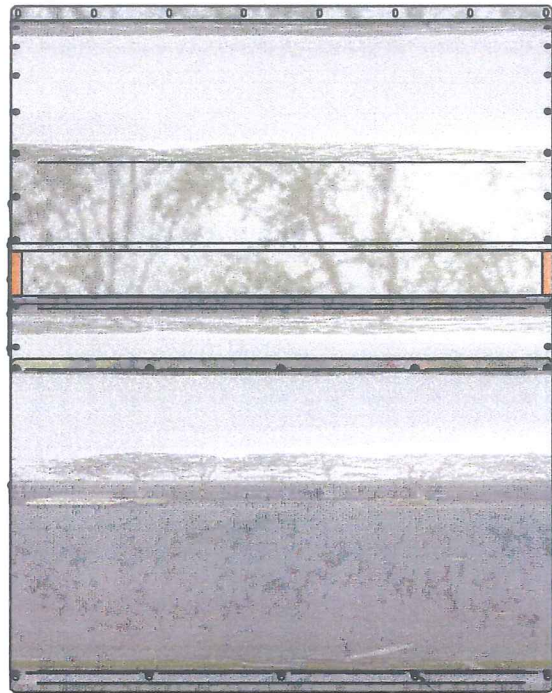

COMPLETE ASSEMBLY, FRONT VIEW

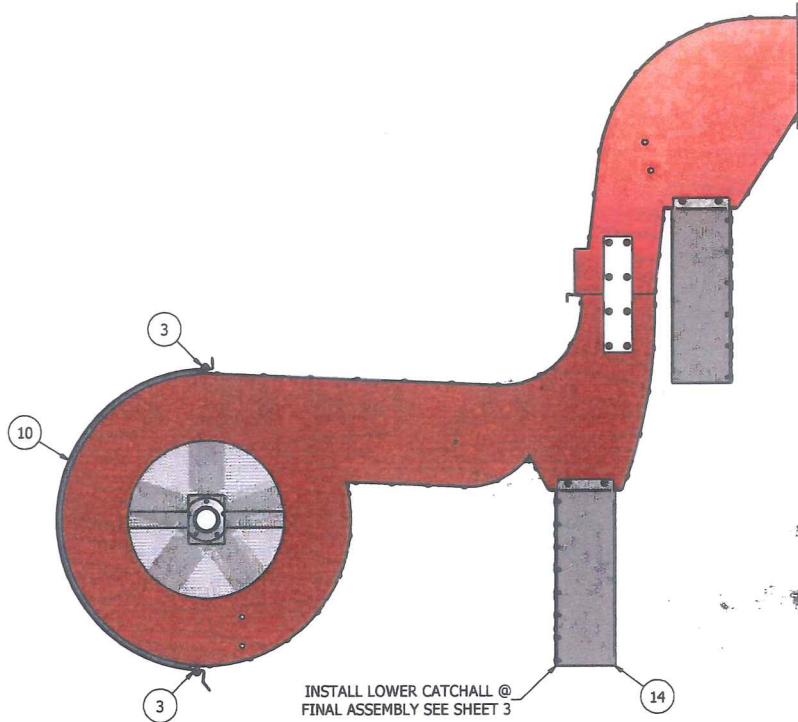

INSTALL LOWER CATCHALL @ FINAL ASSEMBLY SEE SHEET 3

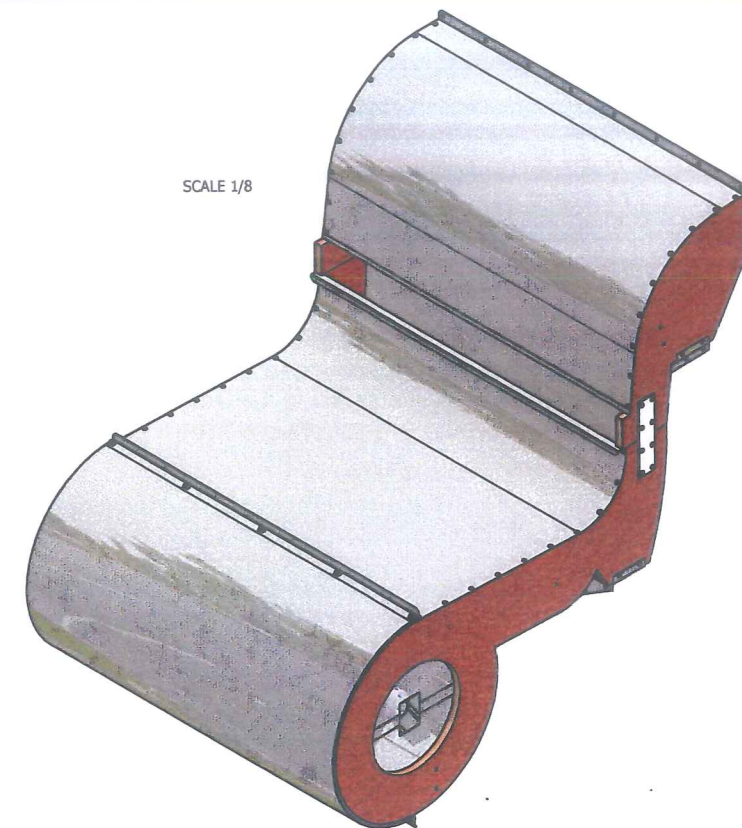

SCALE 1/8

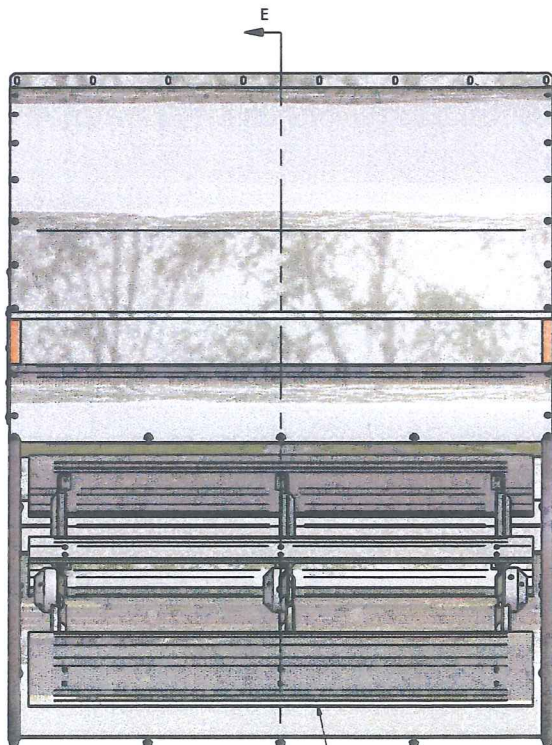

STEP #7-FAN INSTALLATION, FRONT VIEW

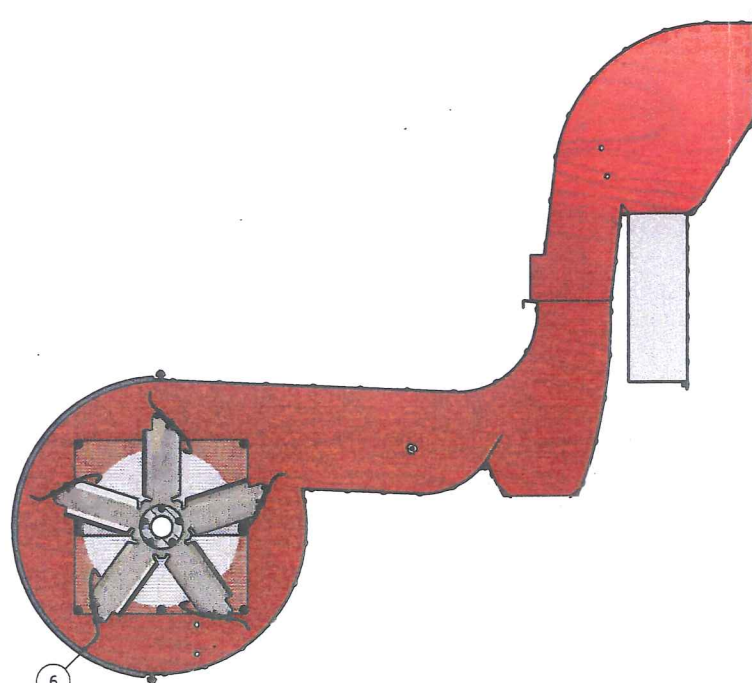

SECTION E-E

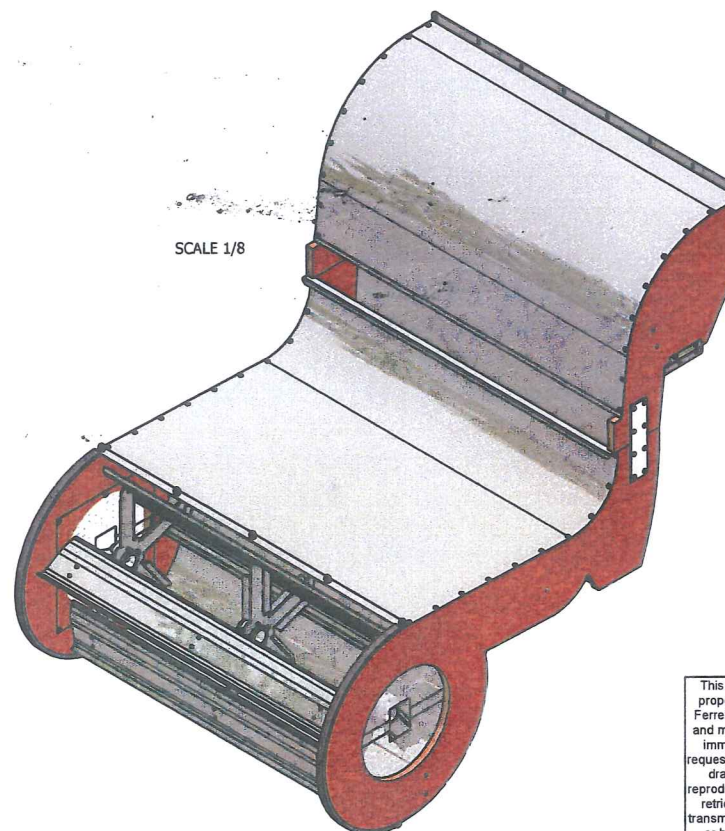

SCALE 1/8

ITEM	PART NUMBER	QTY	DESCRIPTION
20	F83453402	140	SMS, PHP PAN HD #8 X 3/4"
19	F83200011	8	RIVET, POP SDS64 .188X.125-.250
18	F61003099	4	GUARD, INLET, BTM FAN, CONQUEST
17	F60002118	1	DEFLECTOR, AIR, FAN HSG, ECLIPSE 334
16	F60002117	2	SIDE, HOOD, FAN HOUSING, ECLIPSE 334
15	F60002115	1	WRAPPER, LOWER, FAN SCROLL, ECLIPSE 334
14	F60002113	2	CATCHALL ASSY, ECLIPSE 334
13	F60002112	1	WRAPPER, UPPER, FAN HOOD, ECLIPSE 334
12	F60002111	1	WRAPPER, LOWER, FAN HOOD, ECLIPSE 334
11	F60002110	1	WRAPPER, REAR, FAN TRANS, ECLIPSE 334
10	F60002109	1	HATCH, FAN HOUSING, ECLIPSE 334
9	F60002108	1	WRAPPER, LOWER, FAN TRANS, ECLIPSE 334
8	F60002107	1	WRAPPER, UPPER, FAN SCROLL, ECLIPSE 334
7	F60002105	2	SIDE, FAN HOUSING, ECLIPSE 334
6	F60002101	1	FAN WHEEL ASSY, ECLIPSE 334
5	F07303500	2	IRON, STRAP, SETTLING CHAMBER 2 X 8"
4	80014003	2	TAPE, POLYURETHANE, 3/4 X 5/16 X 36.00"
3	66783300	10	NUT, HEX SERR LOCK 1/4-20
2	66402200	20	WASHER, FLAT #8
1	66383300	2	NUT, T 1/4-20 PLT

This drawing is the property of the A.T. Ferrell Company, Inc and must be returned immediately upon request. No part of this drawing may be reproduced, stored in a retrieval system or transmitted in any form or by any means, without prior written consent of the A.T. Ferrell Company, Inc

CAD
NO MANUAL CHANGES
TOLERANCES EXCEPT AS NOTED

DECIMAL: .005 ± .005
FRACTIONAL: 1/32 ± 1/32
ANGULAR: 1/2° ± 1/2°

DIVISION OF A. T. FERRELL COMPANY
FINISH: NONE
SCALE: 0.16:1
DRAWN BY: dmjohnson
DATE: 3/20/2008
SIZE: D
PART NUMBER: F60002100

BLUFFTON, INDIANA - USA
APPROVED BY: DMJ

TITLE: HOUSING ASSY, FAN, ECLIPSE 334

SHEET: 4 of 4

- NOTES:
1. DO NOT SCALE FROM DRAWING.
2. ONE PIECE REQUIRED PER F60000100: CLEANER ASSY, ECLIPSE 334.