

2

1

REVISION HISTORY

REV	ECN	DESCRIPTION	DATE	APPROVED
A	F130105	RELEASE PRINT	7/15/2013	DAD

35	F92401080	3	BEARING, PB 1.500" VAK
34	F91912068	1	SHEAVE SDS 1B6.8
33	F82700050	2	RIBBON, CLOTH .88 X 1.50"
32	F80003558	2	DECAL, LUBRICATION INFO
31	F61008030	1	AIR LEG W/BTM FAN WLDMT/ASSY 1360/1386/486
30	F61003099	8	GUARD. INLET, BTM FAN, CONQUEST
29	F61003064	1	FRAME MNT, LH, BTM DUAL FAN, CONQUEST
28	F61003063	1	FRAME MNT, RH, BTM DUAL FAN, CONQUEST
27	F61003055	1	HOUSING WLDMT, BOTTOM DUAL FAN, CONQUEST
* 26	F61003030	1	MTR PKG, 230V BTM FAN
25	F61003028	1	SUPPORT, GUARD, BOTTOM FAN, CONQUEST 586
24	F61003027	1	PLATE, MOTOR MOUNT, BTM FAN, CNQST
23	F61003026	1	GUARD, BOTTOM FAN, CONQUEST
22	F61003025	1	BACKPLATE, GUARD, BOTTOM FAN, CONQUEST
21	F61003018	1	SHAFT, 1.500" DIA, BOTTOM FAN, CONQUEST
20	F03805600	2	RUBBER HOLD-DOWN STRIP, 1.75"
19	80003643	1	DECAL, WARNING, BELT & CHAIN
18	80003642	6	DECAL, WARNING, FAN BLADE
17	66783800	68	NUT, HEX SERR LOCK 5/16-18
16	66783300	2	NUT, HEX SERR LOCK 1/4-20
15	66445200	6	WASHER, LOCK HELICAL 1/2"
14	66444400	6	WASHER, LOCK HELICAL 3/8"
13	66405200	10	WASHER, FLAT, TYPE A, 1/2"
12	66402200	26	WASHER, FLAT, #8
11	66085200	6	NUT, HEX 1/2-13
10	65683817	22	HHCS, SERR WASHER HEAD, 5/16-18 X 3/4"
9	65483317	2	SCW, MACH HX WSH HD T/C 1/4-20 X 3/4"
8	65483312	4	SCW, MACH HX SLT HD T/C 1/4-20 X 1/2"
7	65482212	30	SCW, MACH HX SLT HD T/C 8-32 X 1/2"
6	65404422	6	SCW, MACH 3/8-16 X 1/00" HX HD T/C
5	62585257	4	HHCS, 1/2-13 X 5.50"
4	62585230	2	HHCS, 1/2-13 X 1.75"
3	62583317	2	HHCS, 1/4-20 X 3/4"
2	49000820	1	KEY, SQUARE 3/8 X 1.25"
1	44010518	1	BUSHING, QD SDS 1.500"
ITEM	PART NUMBER	QTY	DESCRIPTION

B

F61003051

B

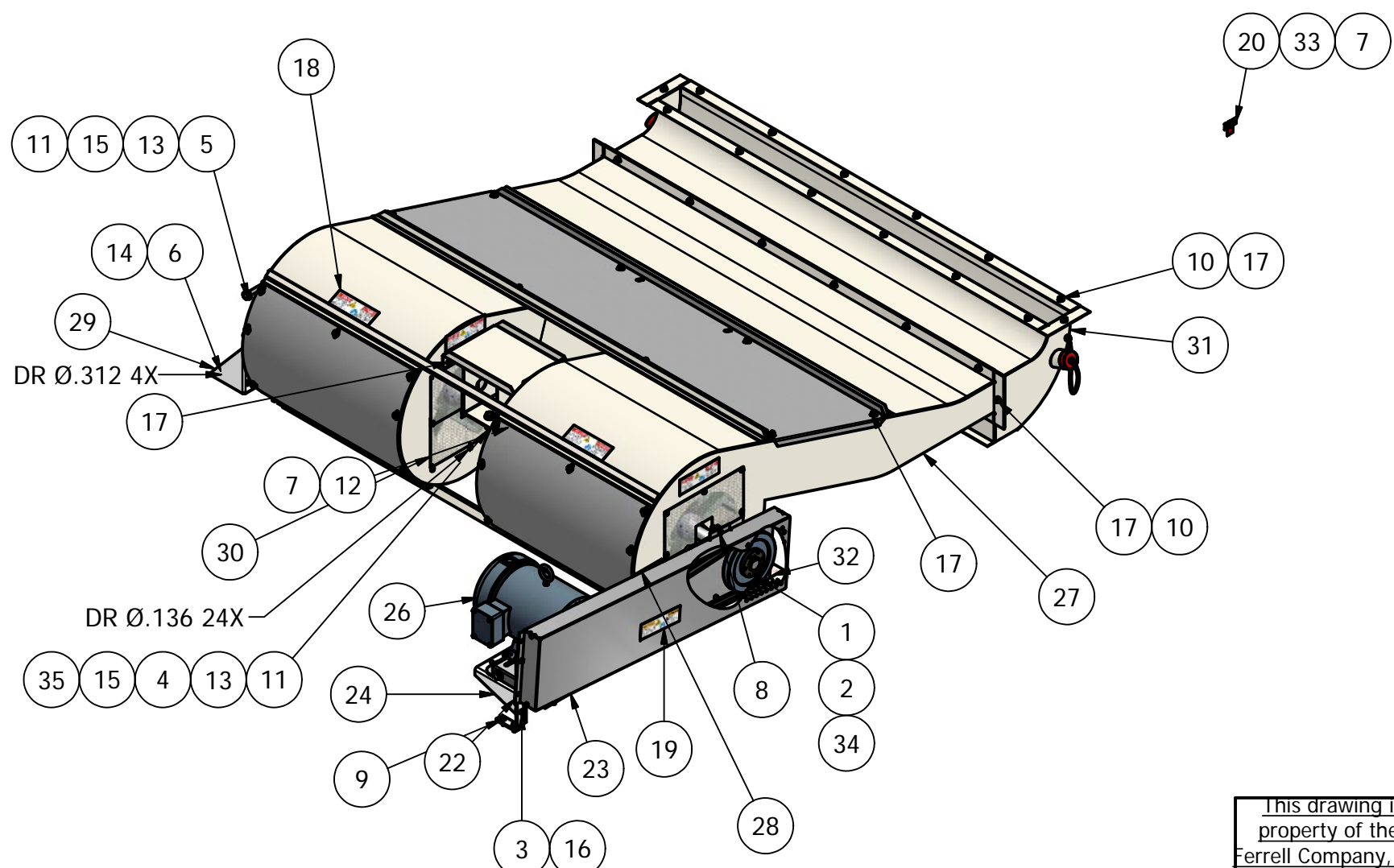

A

A

- NOTES:
- DO NOT SCALE FROM DRAWING.
  - RIGHT HAND DRIVE SHOWN, LEFT HAND DRIVE SYM OPP, SEE SALES ORDER.
  - PROGRAM INVERTER 1000 MAX RPM AT FAN SHAFT.
  - REMOVE PLUG FROM LOWER AIR CHAMBER. ATTACH RIBBON ABOVE HOLE, ALLOWING RIBBON TO SWING FREELY.
  - \* LINE ITEM ON SALES ORDER. NOT INCLUDED IN BILL OF MATERIAL.

This drawing is the property of the A.T. Ferrell Company, Inc and must be returned immediately upon request. No part of this drawing may be reproduced, stored in a retrieval system or transmitted in any form or by any means, without prior written consent of the A.T. Ferrell Company, Inc

<b>CAD</b>				DIVISION OF A. T. FERRELL COMPANY		BLUFFTON, INDIANA - USA	
NO MANUAL CHANGES				FINISH: NONE		SCALE: 0.06:1	
TOLERANCES EXCEPT AS NOTED		DECIMAL: xxx ± .005 xx ± .030		DATE: 7/15/2013		PART NUMBER: F61003051	
FRACTIONAL: ± 1/32		ANGULAR: ± 1/2~		TITLE: FAN ASSY, BOTTOM DUAL, CONQUEST 586		APPROVED BY: DMJ	
				SHEET: 1 of 2			

2

1