

REVISION HISTORY				
REV	ECN	DESCRIPTION	DATE	APPROVED
A	F120010	RELEASE PRINT	3/1/2012	dmjohnson

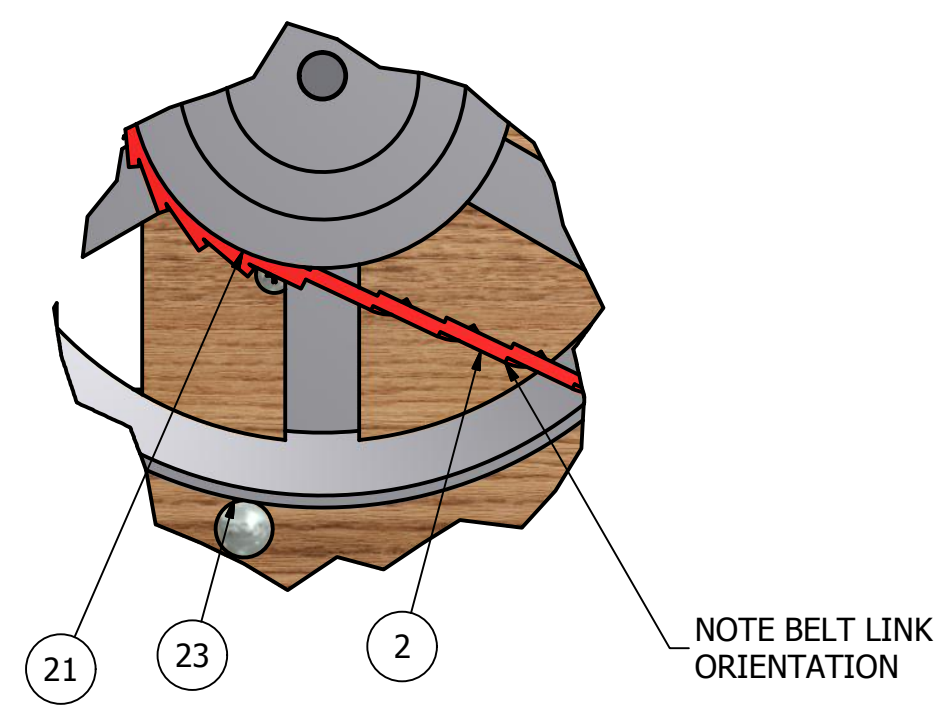

DETAIL A
SCALE 1/2

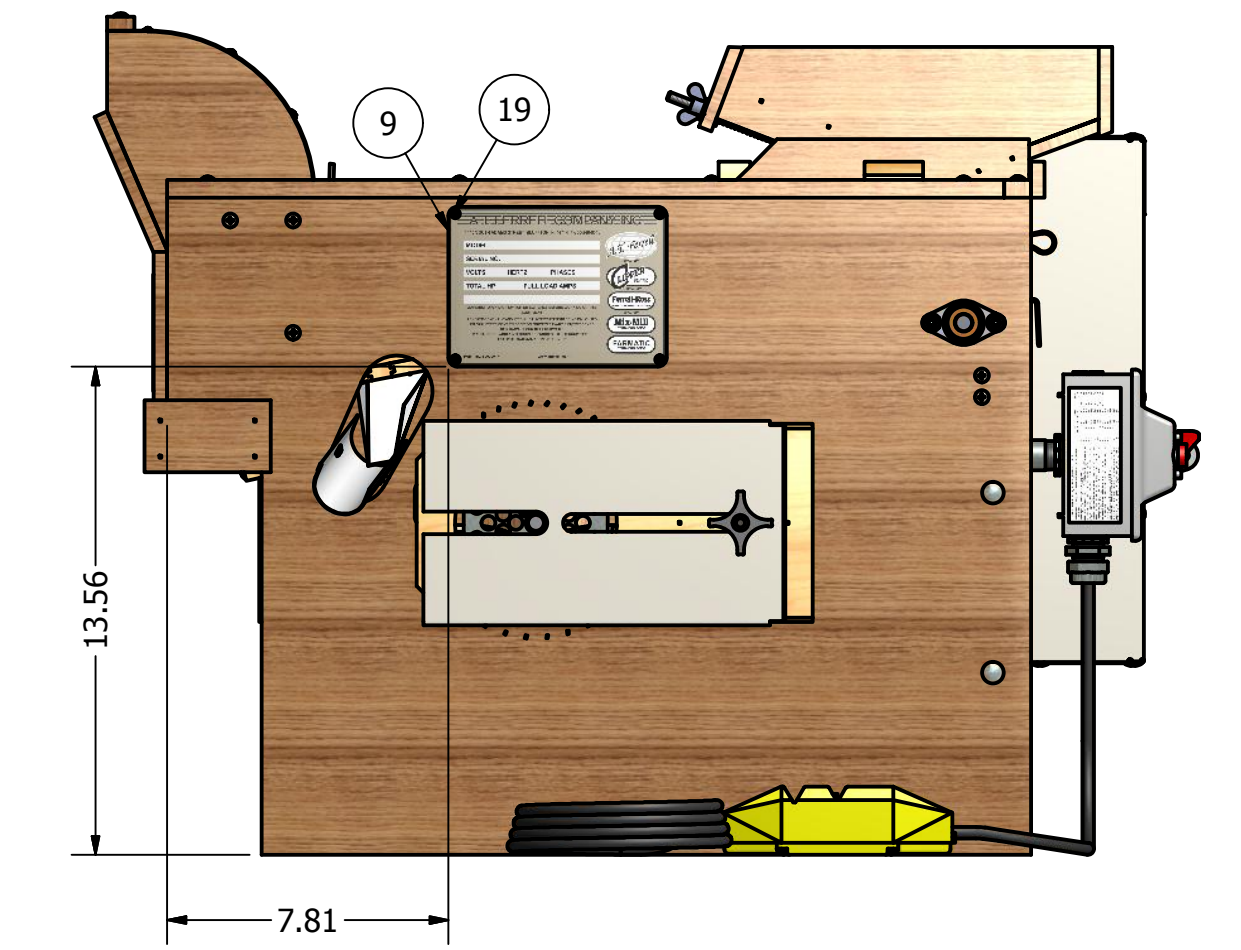
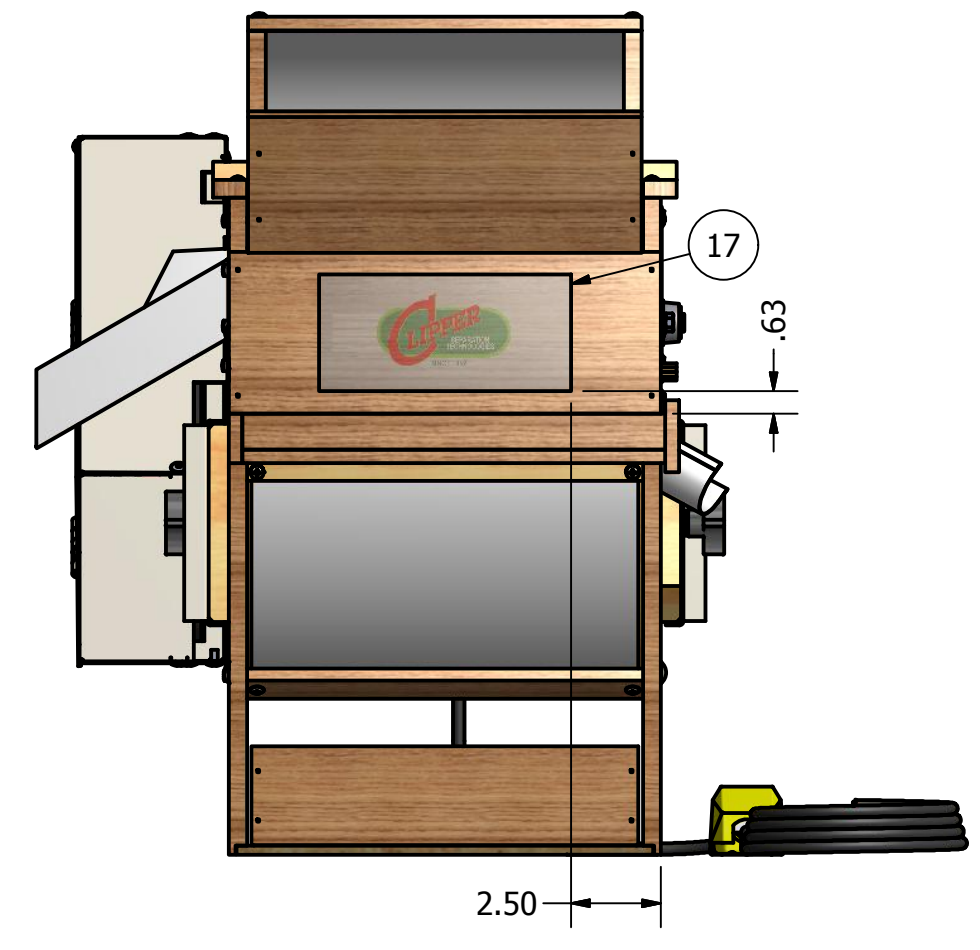
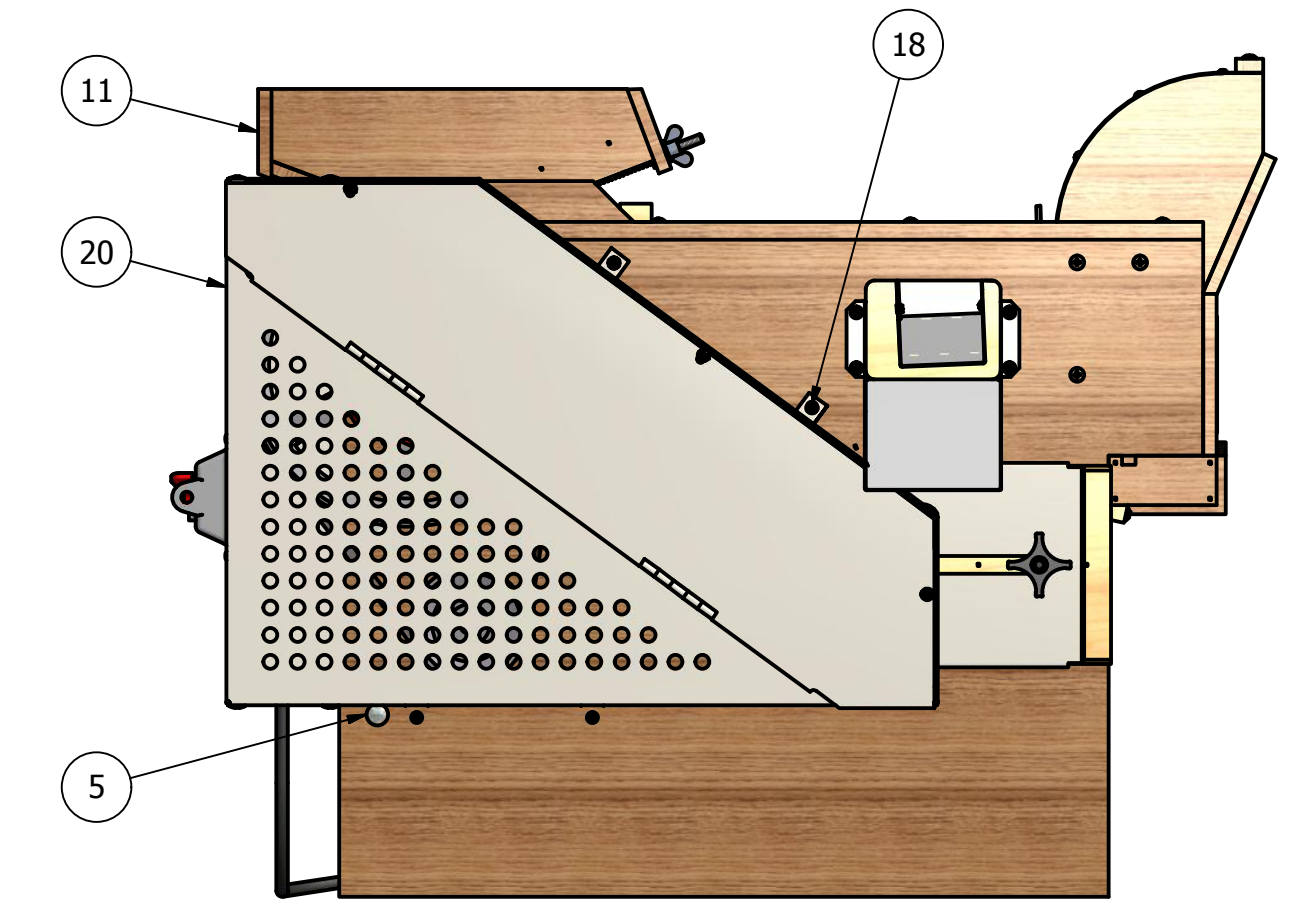
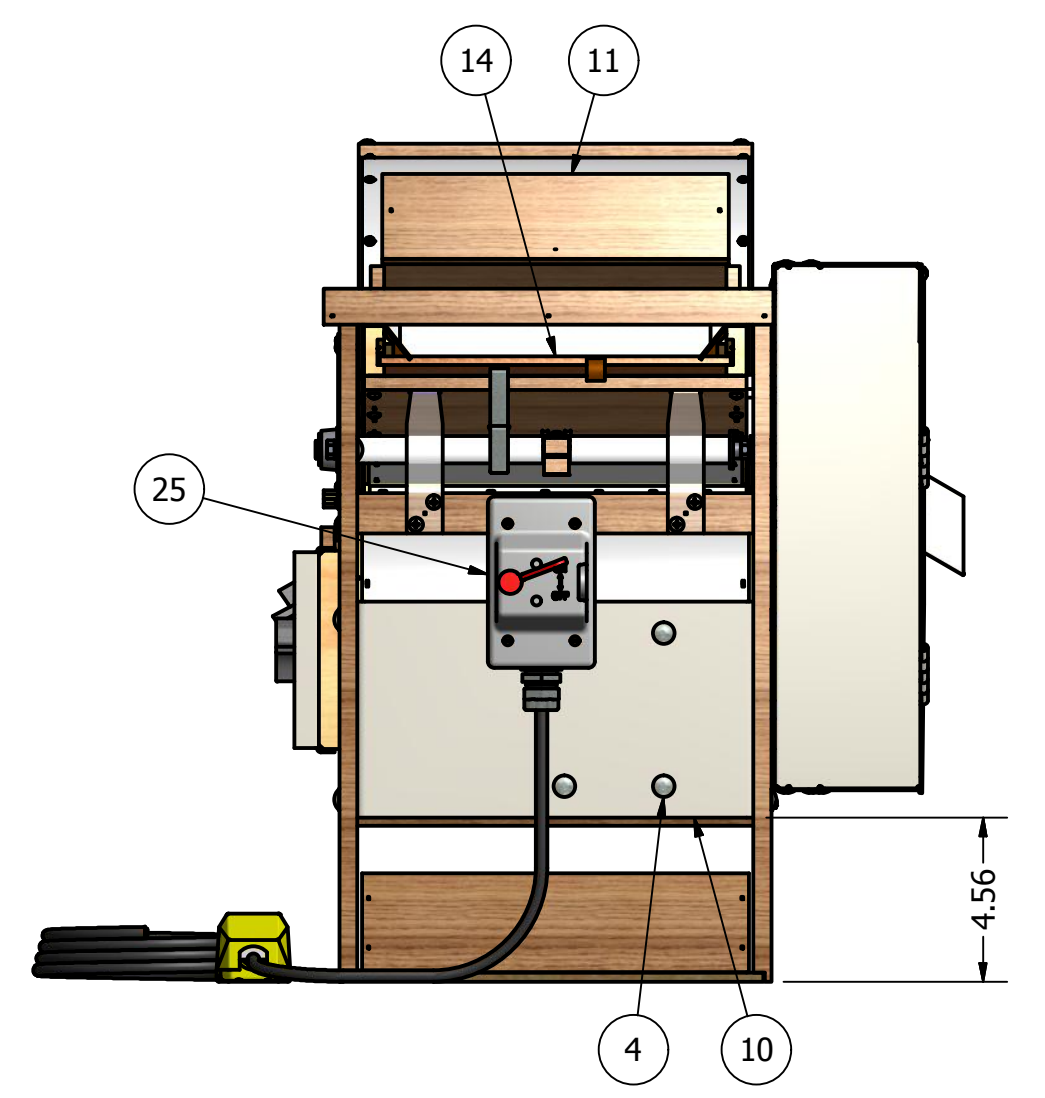
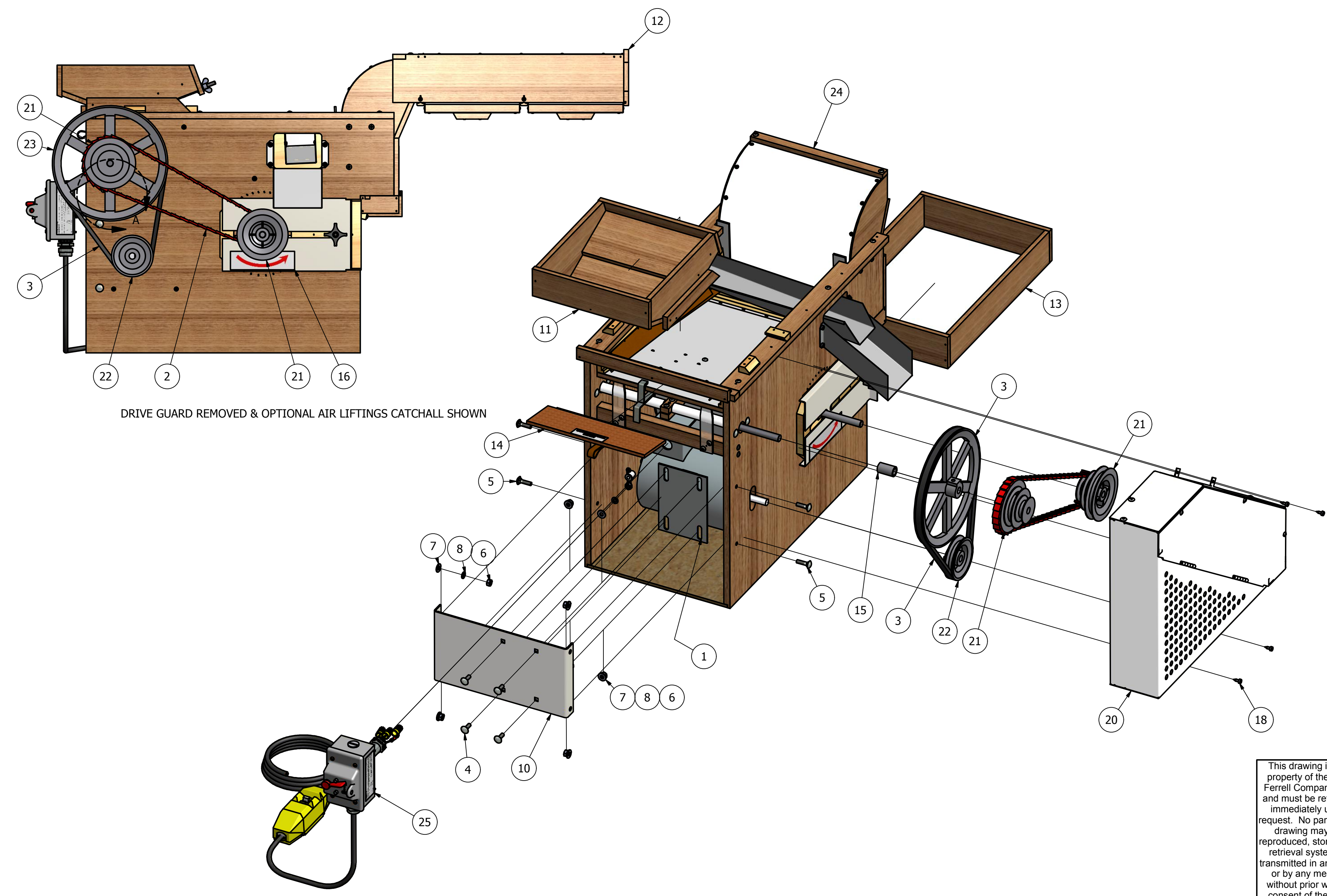

DRIVE GUARD REMOVED & OPTIONAL AIR LIFTINGS CATCHALL SHOWN

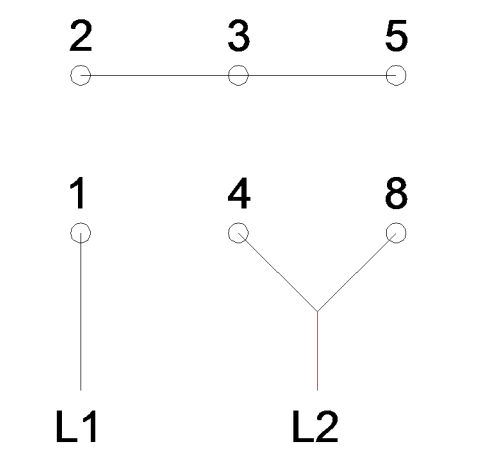

230V MOTOR WIRING

ITEM	PART NUMBER	QTY	DESCRIPTION
25	F92050330	1	WIRING ASSY, 50/60 HZ 230V, OFFICE TESTER
24	F92050306	1	CLEANER ASSY, W/O SCREEN & DRV, OFFICE TESTER
23	F91800033	1	SHEAVE, 1A, .500 X 9.00"
22	F91760325	1	SHEAVE, A, 0.500 X 3.25"
21	F91760033	2	SHEAVE, A, 3 STEP, .500 X 3.75"
20	F90005070	1	GUARD ASSY, DRIVE, OFFICE TESTER
19	F83451205	4	SMS, PAN X HD, #4 X 1/2"
18	F83451201	4	SMS, PAN X HD, #8 X 1/2"
17	F80003616	1	DECAL, "CLIPPER" 2.25 X 7.00"
16	F80003612	1	DECAL, ARROW, LEFT
15	F25301604	1	SPACER, LONG, OFFICE TESTER
14	F25101902	1	BLANK ASSY, SIFT SCREEN, OFFICE TESTER
13	F25000700	1	GRAIN BOX ASSY, OFFICE TESTER
12	F25000600	1	CATCHALL ASSEMBLY, OFFICE TESTER
11	F25000500	1	HOPPER ASSEMBLY, OFFICE TESTER
10	F11302470	1	MOTOR MOUNT, OFFICE TESTER
9	80020017	1	PLATE, BUILD: CLIPPER, FERRELL-ROSS
8	66443300	8	WASHER, LOCK HELICAL 1/4"
7	66403300	8	WASHER, FLAT, 1/4"
6	66083300	8	NUT, HEX 1/4-20
5	60283322	4	BOLT, CARR 1/4-20 X 1.00"
4	60283317	4	BOLT, CARR 1/4-20 X 3/4"
3	45001035	1	BELT, V-A33
2	40000521	3.000 ft	BELT, V-A/4L 1/2" POWER TWIST, 36.00"
1	33001105	1	MTR, .25HP 1D18 5/6 115/230V TENV

- NOTES:
- DO NOT SCALE FROM DRAWING.
 - MOTOR TO BE WIRED FOR COUNTER CLOCKWISE ROTATION.
 - 1Ø 50 HZ 230V PLUG TO BE SUPPLIED BY CUSTOMER & FIELD WIRED.
 - * LINE ITEM ON SALE ORDER. NOT INCLUDED IN BILL OF MATERIAL.

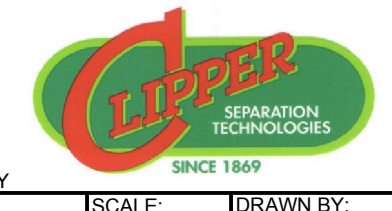
This drawing is the property of the A.T. Ferrell Company, Inc and must be returned immediately upon request. No part of this drawing may be reproduced, stored in a retrieval system or transmitted in any form or by any means, without prior written consent of the A.T. Ferrell Company, Inc	CAD NO MANUAL CHANGES			
	TOLERANCES EXCEPT AS NOTED	DIVISION OF A. T. FERRELL COMPANY	BLUFFTON, INDIANA - USA	
	DECIMAL: .005 .010 .020 .030 FRACTIONAL: 1/32 ANGLUAR: 1/2	FINISH: NONE	SCALE: 1:5	DRAWN BY: dmjohnson APPROVED BY: DMJ
	TITLE: CLEANER ASSY, 50 HZ 230V, OFFICE TESTER		DATE: 2/21/2012	SIZE: D PART NUMBER: F92050311 SHEET: 1 of 1